

KRYO THERM

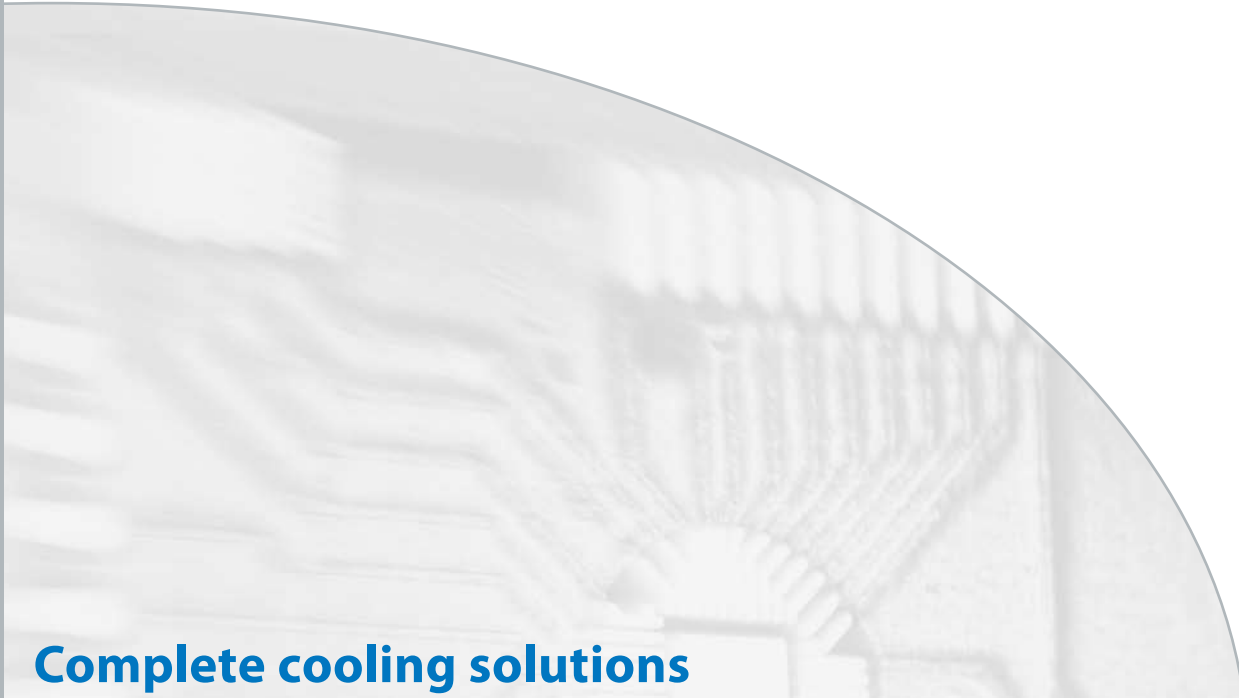

Complete cooling solutions

Thermoelectric coolers and related subsystems

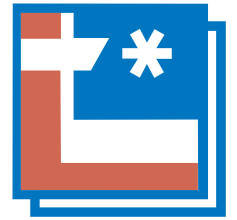



We would like to introduce KRYOTHERM Company that produces thermoelectric coolers and cooling and energy generating subsystems. Owing to high performance, ease of handling, and environmental safety, the thermoelectric coolers and subsystems produced by KRYOTHERM are able to meet the exacting needs of our customers. Our products have found application in radio-electronics, telecommunications, medicine, science, and other fields. They are also used for industrial and commercial markets.

Our company has more than 30-year experience in the research into thermoelectric cooling and energy conversion. For the last 15 years the KRYOTHERM's activities have been directed towards developing, popularizing, and advancing the thermoelectric knowledge and solutions and providing the most modern and up-to-date thermoelectric products to our customers.

The highest priority issues for KRYOTHERM are:

- to develop and fabricate effective, reliable, and safe thermoelectric products
- to perform research works aimed at improvement of our products
- to provide the best service and full engineering support to customers
- to meet the customer's expectations in the most efficient way.

KRYOTHERM has become a provider of thermoelectric coolers to customers all over the world, is steadily increasing the production volume, and has achieved a highly efficient and fruitful cooperation with our partners.

High quality of our products, professionalism of the personnel, and financial stability of the Company make KRYOTHERM a reliable and beneficial partner.



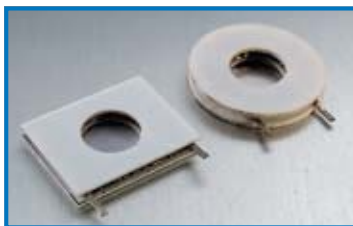
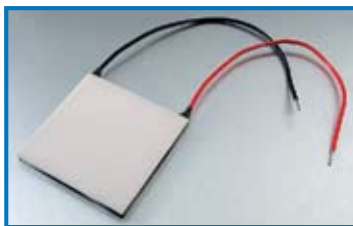
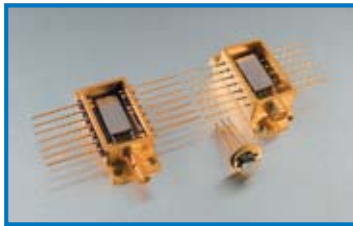

Annotation	2
Principles of TEC operation.	6
Coolers for industrial applications	8
Coolers for radio electronics	16
Multistage thermoelectric coolers	18
Coolers for domestic refrigerating devices	22
Special thermoelectric coolers	24
Generating thermoelectric modules	26
Thermoelectric cooling assemblies	28
Company profile	30
Quality control system.	32
Assembly instructions	36
“Kryotherm” Software	41
Customer request form	42



At present thermoelectric coolers are extensively used in such high-technology fields as telecommunications, electronics, space, medicine, and others. Modern laser, optical, and radioelectronic systems cannot be built without thermoelectric cooling and thermostatically controlled systems. Thermoelectric coolers are also widely used in such consumer goods as portable refrigerators, freezers, water coolers, compact air conditioners, etc.

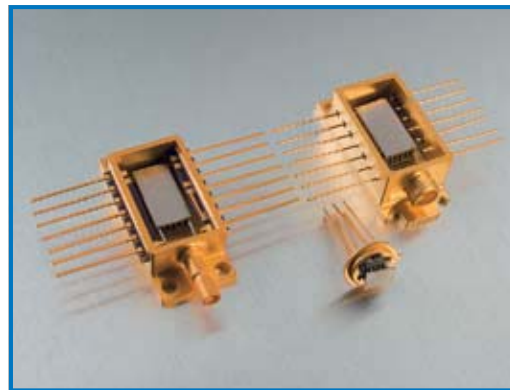

Presently companies worldwide demand compact, noiseless and reliable systems for industrial cooling and temperature control. Thermoelectric coolers (TEC), as semiconductor devices, that utilize the Peltier effect, meet all of the mentioned requirements.

Great promise is offered by the use of TECs for energy generation. A thermoelectric generator allows electricity to be obtained from any heat source.

Benefits of thermoelectric coolers:

- no moving elements
- environmental safety
- no working fluids and gases
- low-noise operation
- reduced size and weight



- high reliability — KRYOTHERM guarantees lifetimes of more than 200 000 hours for our TECs
- smooth and fine adjustment of cooling capacity and temperature
- resistance to mechanical loads
- operation in any spatial position
- easy switching from cooling to heating mode

All these advantages make thermoelectric coolers highly popular, that is confirmed by a growing demand for these components all over the world.



Modern laser, optical, and radioelectronic systems cannot be built without thermoelectric cooling and thermostatically controlled systems.





Basic applications of thermoelectric coolers and assemblies:

- radio electronics — miniature coolers for electronic instruments
- medicine — portable thermostats, medical instruments and equipment
- scientific and laboratory equipment
- consumer goods — portable refrigerators, water coolers etc.
- air-conditioning systems — thermoelectric conditioners, devices for temperature stabilization of electronic units, etc.



The KRYOTHERM catalogue includes more than 250 types of thermoelectric coolers grouped according to the application area.

We produce thermoelectric coolers from 3.4 mm × 3.4 mm to 62.0 mm × 62.0 mm in size with cooling capacity from 0.4 W to 310 W.





Abbreviations and definitions

TEC	thermoelectric cooler
TGM	generating thermoelectric module
ΔT_{max}	maximum achievable temperature difference between the hot and cold side of a thermoelectric cooler
I_{max}	input current through a thermoelectric cooler resulting in greatest ΔT (ΔT_{max})
U_{max}	voltage on a thermoelectric cooler contacts at ΔT_{max}
Q_{max}	maximum cooling capacity of a thermoelectric cooler. It is determined at maximum current through a thermoelectric cooler and at zero temperature difference between hot and cold sides
R_{ac}	electric resistance of a thermoelectric cooler measured at an alternating current with the frequency of 1 kHz





Principles of TEC operation

The first thermoelectric phenomenon was discovered by French physicist and meteorologist Jean Peltier (1785–1845). The basic idea behind the Peltier effect is that whenever DC flows through the circuit of heterogeneous conductors, heat is either released or absorbed at the conductors' junctions, which depends on the current polarity. The amount of heat is proportional to the current that passes through conductors.

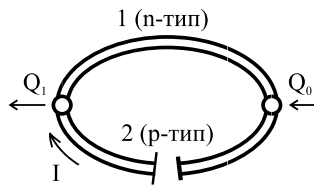

Circuit Diagram Illustrating Peltier Effect

As a result of works performed by Russian academician A.F. Ioffe and his colleagues the semiconducting alloys were synthesized allowing to apply this effect in practice and to begin the full-scale production of thermoelectric refrigerating devices for wide use in various fields of human activities.

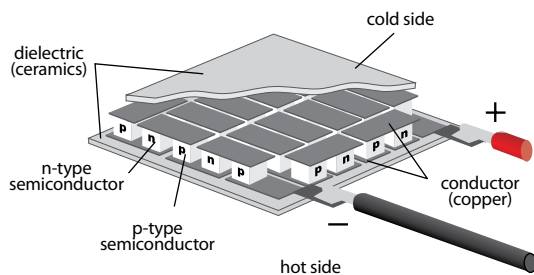

The basic TEC unit is a thermocouple, which consists of a p-type and n-type semiconductor elements, or pellets. Copper commutation tabs are used to interconnect pellets, that are traditionally made of Bismuth Telluride-based alloy.

Thus, a typical TEC consists of thermocouples connected electrically in series and sandwiched between two Alumina ceramic plates. The number of thermocouples may vary greatly — from several elements to hundred of units. This makes it possible to construct a TEC of a desirable cooling capacity ranging from fractions of Watts to hundreds of Watts.

When the constant electrical current passes through the thermoelectric module the temperature difference is generated between its sides — one (cold) side is cooled, another (hot) side is heated. If efficient heat withdrawal is provided for on TEC hot side, for example, by heatsink, the temperature can be obtained on its cold side being by tens of degrees below the ambient temperature. The rate of cooling will be proportional to amount of current. In case the current changes its polarity hot and cold sides are swapped round.

Modern single-stage thermoelectric refrigerators permit to obtain the temperature difference up to 74–76K. In order to obtain lower temperatures the multistage units are applied comprising several single-stage units with series thermal interconnection. For example, serial four-stage TECs produced by Kryotherm permits to develop the temperature difference up to 140K.

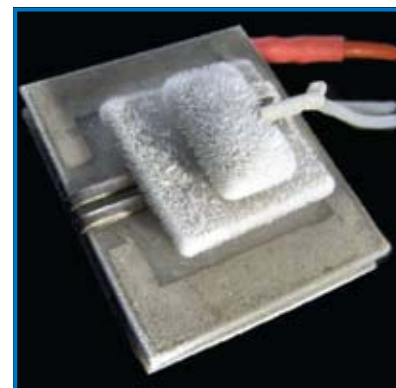
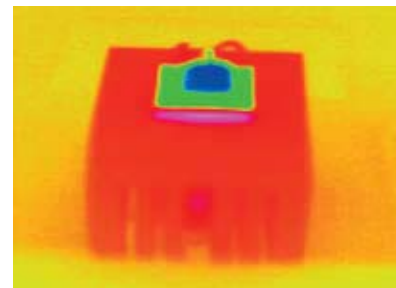
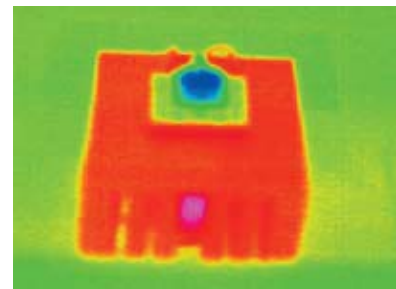

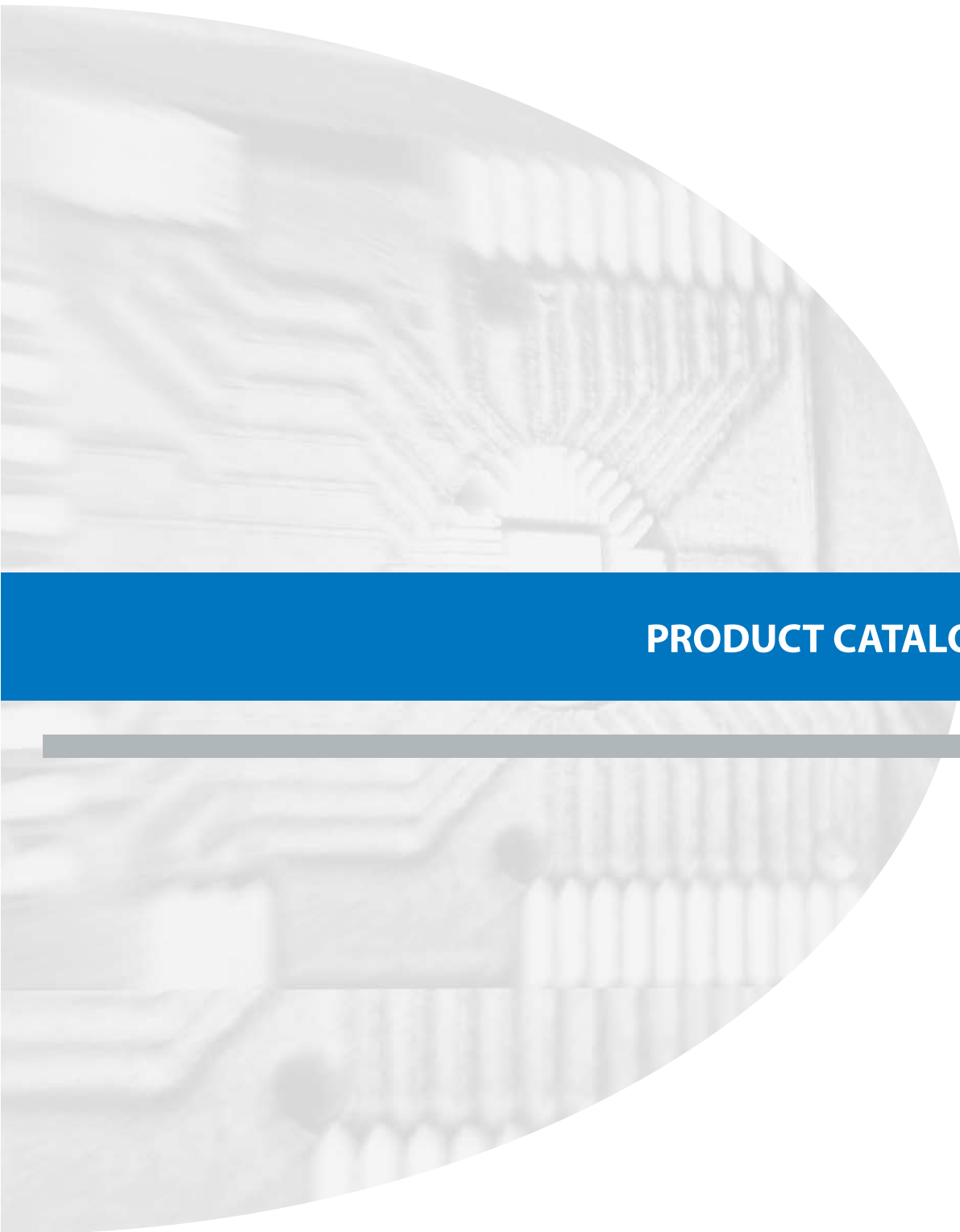

PRODUCT CATALOGUE





Coolers for industrial applications

Designed to be used in the industrial systems of cooling and temperature control.

Main fields of application:

- industrial electronics and telecommunications
- thermoelectric cooling assemblies and conditioners with different functions
- thermoelectric cooling devices for cupboards and electronic equipment blocks
- systems of temperature control of the critical parts and components of different lathes and machines
- heat flow probes

Production of semiconductor integrated micro chips

- installation of active heat cycling for check up of the microprocessors and other micro schemes
- water coolers (chillers) for semiconductor industry
- heat and cold chambers for climatic tests of the radio electronic components

Laser equipment

- cooling systems for industrial and medical lasers and power sources for them

Medical equipment

- built-in refrigerators and conditioners for medical equipment
- mobile containers with temperature control for storage and transportation of the biological materials
- systems of the temperature cycling for genetic engineering and PCR-diagnostics
- devices for recovering and preventive therapy

Transport

- refrigerators and water coolers for cars, railway vehicles, launches and yachts
- local systems of conditioning and climatization

Food industry

- cooling devices for industrial production, storage and transportation of foodstuff
- water, beverage, beer coolers for restaurants, bars and cafes

Special equipment

- solid-state refrigerators and conditioners
- systems of temperature control for spacecrafts

Thermo electric coolers for industrial applications face higher requirements in efficiency, reliability, production accuracy and field performance data.

Special TECs (with a "C" index) are produced for operation under temperature cycling conditions – rapid periodic (up to hundreds of thousands of cycles) changes of temperature of one or both sides of thermoelectric cooler in a wide (several tens of degrees) range of temperatures.

We also produce thermoelectric coolers designed for operation in high temperatures, pressures, humidity, and fine vacuum.

Thermoelectric modules and systems, produced by KRYOTHERM, fit all the modern industrial standards and special requirements. The quality and reliability of TECs are verified by numerous tests performed according to the system of quality accepted at the enterprise. Every batch of TECs is produced in one-to-one correspondence with the customers' specification and is tested according to a program, confirmed by the customer.

Technological features:

According to RoHS directive requirements, serial thermoelectric coolers do not contain lead or any other forbidden materials.



KRYOTHERM produces a wide range of thermoelectric coolers that can be used in industrial applications. Consider our highly effective TEC with which you can solve most of the problems in industrial cooling.

Coolers for industrial applications

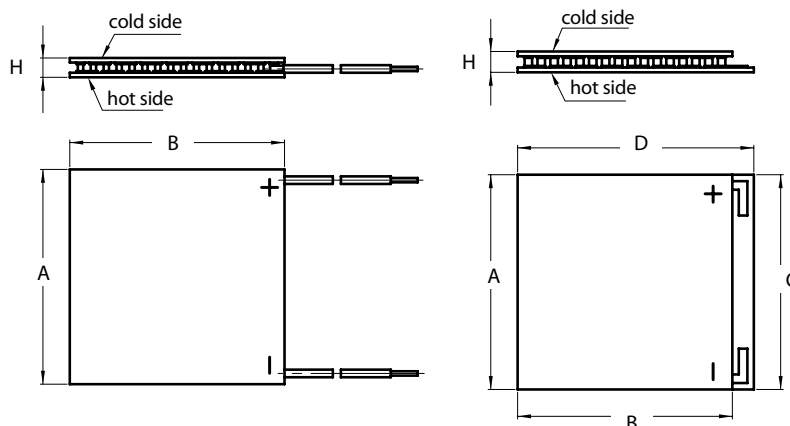

High effective single stage thermoelectric coolers

Type	I_{max}	Q_{max}	U_{max}	ΔT_{max}	R_{ac}	Dimensions (mm)				
	(Amps)	(Watts)	(Volts)	(K)	(Ohm)	A	B	C	D	H
SNOW BALL-71	3.6	36.0	16.1	71	3.20	30.0	30.0	30.0	30.0	3.6
						30.0	30.0	30.0	34.0	
STORM	3.6	34.5	15.7	69	3.20	40.0	40.0	40.0	40.0	3.6
STORM-71	3.6	36.0	16.1	71	3.20	40.0	40.0	40.0	40.0	3.6
RIME-74	3.8	38.0	16.7	74	3.30	40.0	40.0	40.0	40.0	4.8
FROST-71	6.1	61.0	16.1	71	2.05	40.0	40.0	40.0	40.0	3.9
						40.0	40.0	40.0	44.0	
FROST-72	6.2	62.0	16.3	72	2.05	40.0	40.0	40.0	40.0	3.9
						40.0	40.0	40.0	44.0	
FROST-73	6.2	64.0	16.5	73	2.05	40.0	40.0	40.0	40.0	3.9
						40.0	40.0	40.0	44.0	
FROST-74	6.3	65.0	16.7	74	2.15	40.0	40.0	40.0	40.0	3.9
						40.0	40.0	40.0	44.0	
ICE-71	8.0	80.0	16.1	71	1.50	40.0	40.0	40.0	40.0	3.4
HAIL	7.9	76.0	15.7	69	1.50	48.0	48.0	48.0	48.0	3.4
HAIL-71	8.0	80.0	16.1	71	1.50	48.0	48.0	48.0	48.0	3.4
GLACIER-1.5	6.1	76	20.1	72	2.60	40.0	40.0	40.0	40.0	3.8
						40.0	40.0	40.0	44.0	
GLACIER-2.0	4.6	57.0	20.1	72	3.30	40.0	40.0	40.0	40.0	4.3
						40.0	40.0	40.0	44.0	
DRIFT-2.0	4.5	69.0	24.9	70	4.00	40.0	40.0	40.0	40.0	4.4
DRIFT-1.5	6.1	94.0	24.9	70	3.20	40.0	40.0	40.0	40.0	4.1
DRIFT-1.2	7.6	115.0	24.6	69	2.40	40.0	40.0	40.0	40.0	3.7
DRIFT-1.15	7.9	120.0	24.6	69	2.40	40.0	40.0	40.0	40.0	3.6
DRIFT-1.05	8.6	131.0	24.6	69	2.15	40.0	40.0	40.0	40.0	3.5
DRIFT-0.8	11.3	172.0	24.6	69	1.65	40.0	40.0	40.0	40.0	3.2
						35.0	55.0	35.0	55.0	
DRIFT-0.6	15.1	229.3	24.6	68	1.25	40.0	40.0	40.0	40.0	3.1
CHILL	5.8	56.0	15.7	69	2.00	40.0	40.0	40.0	40.0	3.2



Coolers for industrial applications

System of notation:

A universal abbreviation is used to notate single-stage coolers: **TB-N-C-h**, where:

- TB** — product contraction — thermoelectric battery (cooler);
- N** — number of thermocouples in the cooler;
- C** — length of the rib of the thermoelectric element basis (in millimeters);
- h** — height of the thermoelectric element (in millimeters)

For example, in the module TB-161-1.4-1.5: 161 thermocouples (322 thermoelectric elements), every element has the cross-section of 1.4×1.4 mm and is 1.5 mm high.

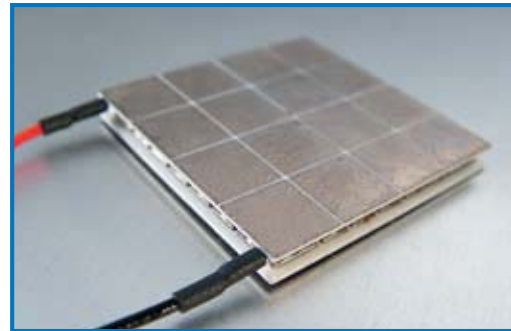

Standard single stage thermoelectric coolers

Type	Imax	Qmax	Umax	ΔTmax	Rac	Dimensions (mm)					Orientation of outputs	
	(Amps)	(Watts)	(Volts)	(K)	(Ohm)	A	B	C	D	H	short side	long side
TB-127-0.8-1.5	2.0	19.1	15.7	69	6.40	25.0	25.0	25.0	25.0	3.8		
TB-7-1.0-2.5	1.9	1.0	0.9	70	0.33	8.0	8.0	8.0	8.0	4.8		
TB-17-1.0-2.5	1.9	2.5	2.1	70	0.85	11.5	11.5	11.5	11.5	4.8		
TB-31-1.0-2.5	1.9	4.5	3.9	70	1.50	14.8	14.8	14.8	14.8	4.8		
TB-63-1.0-2.5	1.9	9.1	7.9	70	3.00	15.0	30.0	15.0	30.0	4.8	+	+
TB-71-1.0-2.5	1.9	10.2	8.9	70	3.35	23.0	23.0	23.0	23.0	4.8		
TB-83-1.0-2.5	1.9	12.0	10.4	70	4.15	22.0	19.0	22.0	19.0	4.8		+
TB-127-1.0-2.5	1.9	18.3	15.9	70	6.20	30.0	30.0	30.0	30.0	4.8		
TB-7-1.0-2.0	2.3	1.3	0.9	70	0.26	8.0	8.0	8.0	8.0	4.3		
TB-17-1.0-2.0	2.3	3.1	2.1	70	0.65	11.5	11.5	11.5	11.5	4.3		
TB-31-1.0-2.0	2.3	5.6	3.9	70	1.25	14.8	14.8	14.8	14.8	4.3		
TB-63-1.0-2.0	2.3	11.4	7.9	70	2.50	15.0	30.0	15.0	30.0	4.3	+	+
TB-71-1.0-2.0	2.3	12.8	8.9	70	2.70	23.0	23.0	23.0	23.0	4.3		
TB-83-1.0-2.0	2.3	14.9	10.4	70	3.20	22.0	19.0	22.0	19.0	4.3		+
TB-127-1.0-2.0	2.3	22.9	15.9	70	4.85	30.0	30.0	30.0	30.0	4.3		
TB-127-1.0-1.8	2.6	24.9	15.7	69	4.35	30.0	30.0	30.0	30.0	4.1		
TB-7-1.0-1.5	3.1	1.7	0.9	69	0.20	8.0	8.0	8.0	8.0	3.8		
TB-17-1.0-1.5	3.1	4.0	2.1	69	0.50	11.5	11.5	11.5	11.5	3.8		
TB-31-1.0-1.5	3.1	7.3	3.8	69	0.90	14.8	14.8	14.8	14.8	3.8		
TB-63-1.0-1.5	3.1	14.8	7.8	69	1.80	15.0	30.0	15.0	30.0	3.8	+	+
TB-71-1.0-1.5	3.1	16.7	8.8	69	2.05	23.0	23.0	23.0	23.0	3.8		
TB-83-1.0-1.5	3.1	19.5	10.3	69	2.40	22.0	19.0	22.0	19.0	3.8		+
TB-127-1.0-1.5	3.1	29.9	15.7	69	3.65	30.0	30.0	30.0	30.0	3.8		

Coolers for industrial applications



Type	I _{max}	Q _{max}	U _{max}	ΔT _{max}	R _{ac}	Dimensions (mm)					Orientation of outputs	
	(Amps)	(Watts)	(Volts)	(K)	(Ohm)	A	B	C	D	H	short side	long side
TB-7-1.0-1.3	3.6	1.9	0.9	69	0.18	8.0	8.0	8.0	8.0	3.6		
TB-17-1.0-1.3	3.6	4.6	2.1	69	0.42	11.5	11.5	11.5	11.5	3.6		
TB-31-1.0-1.3	3.6	8.4	3.8	69	0.80	14.8	14.8	14.8	14.8	3.6		
TB-63-1.0-1.3	3.6	17.1	7.8	69	1.65	15.0	30.0	15.0	30.0	3.6	+	+
TB-71-1.0-1.3	3.6	19.3	8.8	69	1.80	23.0	23.0	23.0	23.0	3.6		
TB-83-1.0-1.3	3.6	22.5	10.3	69	2.20	22.0	19.0	22.0	19.0	3.6		+
TB-127-1.0-1.3	3.6	34.5	15.7	69	3.20	30.0	30.0	30.0	30.0	3.6	+	
						30.0	30.0	30.0	34.0			
TB-127-1.0-1.3RE	3.6	34.5	15.7	69	3.20	30.0	30.0	30.0	30.0	3.6		
TB-63-1.0-1.15	4.0	19.3	7.8	69	1.42	15.0	30.0	15.0	30.0	3.4	+	+
TB-32-1.0-0.8	5.8	14.1	3.9	68	0.53	40.0	6.0	40.0	6.0	3.1		+
TB-127-1.0-0.8	5.8	56.0	15.7	69	2.05	30.0	30.0	30.0	30.0	3.1		
TB-195-1.0-0.8	5.8	86.0	24.1	68	3.20	50.0	25.0	50.0	25.0	3.1		+
TB-71-1.4-3.175	2.9	16.5	9.1	72	2.35	30.0	30.0	30.0	30.0	5.6		
TB-127-1.4-2.9	3.2	32.3	16.3	72	3.70	40.0	40.0	40.0	40.0	5.2		
TB-7-1.4-2.5	3.7	2.1	0.9	72	0.18	10.0	10.0	10.0	10.0	4.9		
TB-17-1.4-2.5	3.7	5.0	2.2	72	0.45	15.0	15.0	15.0	15.0	4.9		
TB-31-1.4-2.5	3.7	9.1	4.0	72	0.80	20.0	20.0	20.0	20.0	4.9		
TB-48-1.4-2.5	3.6	13.5	6.0	70	1.25	35.0	20.0	35.0	20.0	4.9		+
TB-63-1.4-2.5	3.7	18.6	8.1	72	1.60	20.0	40.0	20.0	40.0	4.9	+	+
TB-71-1.4-2.5	3.7	20.9	9.1	72	1.80	30.0	30.0	30.0	30.0	4.9		
TB-99-1.4-2.5	3.6	27.9	12.4	70	2.45	20.0	40.0	20.0	40.0	4.9	+	+
TB-123-1.4-2.5	3.6	34.6	15.4	70	3.20	40.0	40.0	40.0	40.0	4.9		
TB-127-1.4-2.5	3.7	37.4	16.3	72	3.20	40.0	40.0	40.0	40.0	4.8		
TB-63-1.4-2.0	4.6	22.2	7.9	70	1.25	20.0	40.0	20.0	40.0	4.4	+	+
TB-127-1.4-2.0	4.6	45.0	15.9	70	2.50	40.0	40.0	40.0	40.0	4.3		
TB-161-1.4-2.0	4.6	57.0	20.1	70	3.30	40.0	40.0	40.0	40.0	4.3	+	
						40.0	40.0	40.0	44.0			
TB-71-1.4-1.8	5.1	27.9	8.9	70	1.38	30.0	30.0	30.0	30.0	4.2		
TB-7-1.4-1.5	6.1	3.3	0.9	69	0.11	10.0	10.0	10.0	10.0	4.0		
TB-17-1.4-1.5	6.1	8.0	2.1	70	0.25	15.0	15.0	15.0	15.0	4.0		
TB-31-1.4-1.5	6.1	14.6	3.9	70	0.50	20.0	20.0	20.0	20.0	4.0		
TB-35-1.4-1.5	6.1	16.4	4.4	70	0.58	15.0	30.0	15.0	30.0	4.0	+	+
TB-63-1.4-1.5	6.1	29.7	7.9	70	1.05	20.0	40.0	20.0	40.0	4.0	+	+
TB-71-1.4-1.5	6.1	33.4	8.9	70	1.17	30.0	30.0	30.0	30.0	4.0		
TB-99-1.4-1.5	6.1	46.0	12.4	70	1.70	20.0	40.0	20.0	40.0	4.0	+	+
TB-123-1.4-1.5	6.1	58.0	15.4	70	2.00	40.0	40.0	40.0	40.0	4.0		
TB-127-1.4-1.5	6.1	60	15.9	70	2.05	40.0	40.0	40.0	40.0	3.9	+	
						40.0	40.0	40.0	44.0			
TB-161-1.4-1.5	6.1	76	20.1	70	2.60	40.0	40.0	40.0	40.0	3.9	+	
						40.0	40.0	40.0	44.0			
TB-241-1.4-1.5	6.1	113.8	30.0	70	3.60	55.0	55.0	55.0	59.0	4.0	+	
TB-127-1.4-1.2	7.6	75.0	15.9	70	1.50	40.0	40.0	40.0	40.0	3.5		



Coolers for industrial applications

Type	I _{max}	Q _{max}	U _{max}	ΔT _{max}	R _{ac}	Dimensions (mm)					Orientation of outputs	
	(Amps)	(Watts)	(Volts)	(K)	(Ohm)	A	B	C	D	H	short side	long side
TB-7-1.4-1.15	7.9	4.2	0.9	69	0.09	10.0	10.0	10.0	10.0	3.6		
TB-17-1.4-1.15	7.9	10.2	2.1	69	0.20	15.0	15.0	15.0	15.0	3.6		
TB-31-1.4-1.15	7.9	18.6	3.8	69	0.40	20.0	20.0	20.0	20.0	3.6		
TB-35-1.4-1.15	7.9	21.0	4.3	69	0.40	15.0	30.0	15.0	30.0	3.6	+	+
TB-63-1.4-1.15	7.9	37.9	7.8	69	0.72	20.0	40.0	20.0	40.0	3.6	+	+
TB-71-1.4-1.15	7.9	43.0	8.8	69	0.80	30.0	30.0	30.0	30.0	3.6		
TB-127-1.4-1.15	7.9	76.0	15.7	69	1.50	40.0	40.0	40.0	40.0	3.6		
TB-35-1.4-1.05	8.6	23.0	4.3	69	0.38	15.0	30.0	15.0	30.0	3.4	+	+
TB-99-1.4-1.05	8.6	65.0	12.3	69	1.07	20.0	40.0	20.0	40.0	3.4	+	+
TB-127-1.4-1.05	8.6	84.0	15.7	69	1.40	40.0	40.0	40.0	40.0	3.3		
TB-49-1.4-0.8	11.3	42.0	6.1	69	0.40	21.0	21.0	21.0	21.0	3.2		
TB-99-1.4-0.8	11.3	86.0	12.3	69	0.80	20.0	40.0	20.0	40.0	3.2	+	+
TB-7-2.0-2.5	7.6	4.2	0.9	72	0.09	14.8	14.8	14.8	14.8	4.8		
TB-17-2.0-2.5	7.6	10.2	2.2	72	0.20	22.0	22.0	22.0	22.0	4.8		
TB-31-2.0-2.5	7.6	18.7	4.0	72	0.40	30.0	30.0	30.0	30.0	4.8		
TB-71-2.0-2.5	7.6	43.0	9.1	72	0.87	40.0	40.0	40.0	40.0	4.8		
TB-127-2.0-2.5	7.6	76.0	16.3	72	1.65	48.0	48.0	48.0	48.0	4.8		
						55.0	55.0	55.0	55.0			
						62.0	62.0	62.0	62.0			
TB-127-2.0-1.65	11.3	111.0	15.9	70	1.00	48.0	48.0	48.0	48.0	4.0		
						55.0	55.0	55.0	55.0			
						62.0	62.0	62.0	62.0			
TB-7-2.0-1.5	12.4	6.7	0.9	70	0.06	14.8	14.8	14.8	14.8	3.8		
TB-17-2.0-1.5	12.4	16.3	2.1	70	0.12	22.0	22.0	22.0	22.0	3.8		
TB-31-2.0-1.5	12.4	29.8	3.9	70	0.24	30.0	30.0	30.0	30.0	3.8		
TB-71-2.0-1.5	12.4	68.0	8.9	70	0.52	40.0	40.0	40.0	40.0	3.8		
TB-127-2.0-1.5	12.4	122.0	15.9	70	0.95	48.0	48.0	48.0	48.0	3.8		
						55.0	55.0	55.0	55.0			
						62.0	62.0	62.0	62.0			
TB-71-2.0-1.15	16.1	87.0	8.8	69	0.40	40.0	40.0	40.0	40.0	3.6		
TB-127-2.0-1.15	16.1	156.0	15.7	69	0.75	48.0	48.0	48.0	48.0	3.4		
						55.0	55.0	55.0	55.0			
						62.0	62.0	62.0	62.0			
TB-127-2.0-1.05	17.6	171.0	15.7	69	0.66	48.0	48.0	48.0	48.0	3.3		
						55.0	55.0	55.0	55.0			
						62.0	62.0	62.0	62.0			
TB-199-2.0-0.9	20.6	310.0	24.6	69	0.87	62.0	62.0	62.0	62.0	3.2		
TB-127-2.2-1.15	19.5	189.0	15.7	69	0.58	55.0	55.0	55.0	59.0	3.5	+	
TB-127-2.2-0.95	23.4	223.0	15.5	68	0.51	55.0	55.0	55.0	59.0	3.3	+	
TB-31-2.8-1.5	24.4	58.0	3.9	70	0.13	40.0	40.0	40.0	40.0	4.0		
TB-32-2.8-1.5	24.4	60.0	4.0	70	0.12	40.0	40.0	40.0	40.0	4.0		
TB-31-5.0-1.8	64.0	149.0	3.8	68	0.05	55.0	55.0	55.0	55.0	5.3		
TB-31-5.0-1.5	77.0	178.0	3.8	68	0.04	55.0	55.0	55.0	55.0	5.0		

Coolers for industrial applications

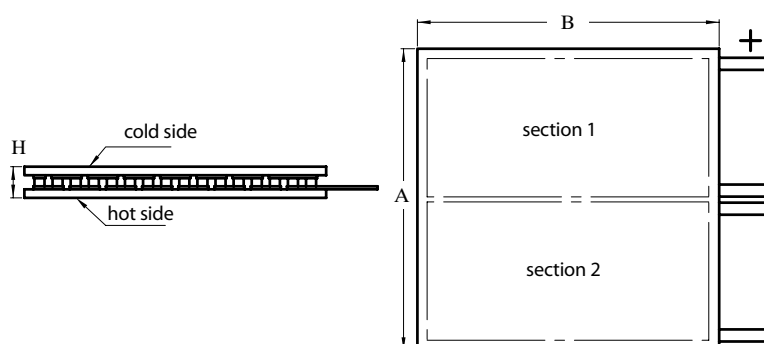
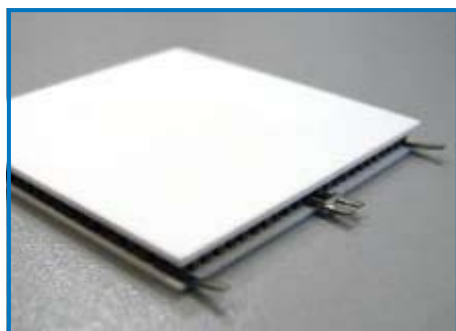

Two section thermoelectric coolers

Units connection	I_{max}	Q_{max}	U_{max}	ΔT_{max}	R_{ac}	Dimensions (mm)		
	(Amps)	(Watts)	(Volts)	(K)	(Ohm)	A	B	H
TURBO-2,5								
Serial	1.85	36.6	31.8	70	12.2	40.0	40.0	4.8
Parallel	3.7	36.6	15.9		3.1			
TURBO-1,5								
Serial	3.1	60.0	31.4	69	7.5	40.0	40.0	3.8
Parallel	6.2	60.0	15.7		1.85			
TURBO-1,3								
Serial	3.6	69.0	31.4	69	6.5	40.0	40.0	3.6
Parallel	7.2	69.0	15.7		1.6			

System of notation:

To notate thermoelectric coolers with a hole a system of notation of standard single-stage thermoelectric coolers with an index is used:

CH — for rectangular modules with a central hole (for example TB-43-1.0-0.8CH)

CHR — for round coolers with a central hole (for example TB-19-1.0-1.3CHR)

R — for round coolers (for example TB-253-1.4-1.5R)

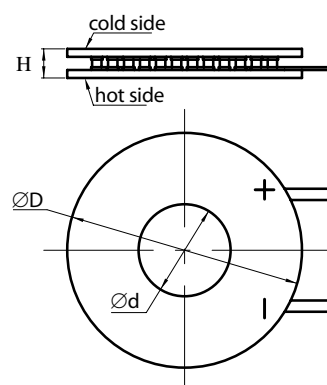

Round thermoelectric coolers with a hole

Type	I_{max}	Q_{max}	U_{max}	ΔT_{max}	R_{ac}	Dimensions (mm)		
	(Amps)	(Watts)	(Volts)	(K)	(Ohm)	D	d	H
TB-19-1.0-1.3CHR	3.6	5.2	2.4	69	0.52	15.0	3.0	3.6
TB-38-1.0-0.8CHR	5.8	16.8	4.7	69	0.64	24.0	9.8	3.1
TB-38-1.0-1.3CHR	3.6	10.3	4.7	69	1.05	24.0	9.8	3.6
TB-38-1.0-1.5CHR	3.1	8.9	4.7	69	1.12	24.0	9.8	3.8
TB-43-1.0-0.8CHR	5.8	19.0	5.3	69	0.70	24.0	5.0	3.1



Coolers for industrial applications

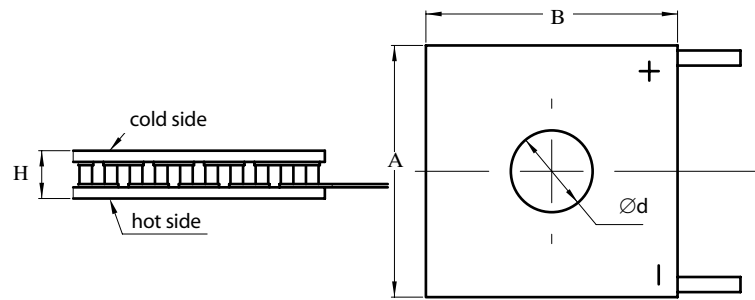

Square thermoelectric coolers with a hole

Type	I_{max}	Q_{max}	U_{max}	ΔT_{max}	R_{ac}	Dimensions (mm)			
	(Amps)	(Watts)	(Volts)	(K)	(Ohm)	A	B	H	d
TB-41-1.0-1.5CH	3.1	9.6	5.1	69	1.20	20.0	20.0	3.8	6.5
TB-43-1.0-0.8CH	5.7	18.6	5.3	68	0.70	22.5	17.5	3.1	9.5
TB-43-1.0-1.3CH	3.6	11.7	5.3	69	1.10	22.5	17.5	3.6	9.5
TB-43-1.0-1.5CH	3.1	10.1	5.3	69	1.20	22.5	17.5	3.8	9.5
TB-119-1.0-1.3CH	3.6	32.3	14.7	69	3.10	30.0	30.0	3.6	4.0
TB-119-1.0-1.5CH	3.1	28.0	14.7	69	3.40	30.0	30.0	3.8	4.0
TB-119-1.0-2.0CH	2.3	21.0	14.7	69	4.90	30.0	30.0	4.3	4.0
TB-40-1.4-1.1CH	8.2	25.1	5.0	69	0.45	23.0	23.0	3.6	9.5
TB-109-1.4-1.5CH	6.1	51.0	13.7	70	1.80	40.0	40.0	4.0	13.0
TB-119-1.4-1.15CH	7.9	72.0	14.7	69	1.40	40.0	40.0	3.4	7.8
TB-119-1.4-1.5CH	6.1	56.0	14.9	70	1.90	40.0	40.0	3.9	7.8
TB-119-1.4-2.5CH	3.7	35.1	15.3	72	3.00	40.0	40.0	4.8	7.8
TB-125-1.4-1.15CH	7.9	75.0	15.5	69	1.50	40.0	40.0	3.4	4.7
TB-125-1.4-1.5CH	6.1	59.0	15.7	70	2.00	40.0	40.0	3.9	4.7
TB-125-1.4-2.5CH	3.7	36.8	16.0	72	3.10	40.0	40.0	4.8	4.7

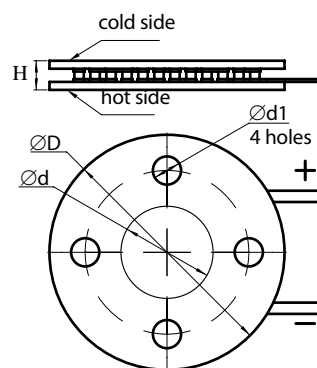

Special round thermoelectric coolers

Type	I_{max}	Q_{max}	U_{max}	ΔT_{max}	R_{ac}	Dimensions (mm)		$d1$ (mm)
	(Amps)	(Watts)	(Volts)	(K)	(Ohm)	D	H	
TB-19-1.0-0.8 R	5.7	8.2	2.3	68	0.34	15.0	2.5	-
TB-253-1.4-1.5 R	6.1	119.0	31.7	70	4.30	62.0	3.9	-
TB-295-1.0-0.8CHR	5.8	130.0	36.5	69	4.60	61.0	3.2	4 edge holes with $\varnothing 7$ mm



Standard terms of delivery:

- substrate material — alumina (BK-96)
- height tolerance ± 0.05 mm (L1)
- parallelism 0.03 mm (L1)
- wire length 120 mm
- pin orientation (for rectangular coolers) — to the longer side
- processing temperature up to 80 °C, maximal assembly temperature 120 °C (assembly solder $T_m = 139$ °C)

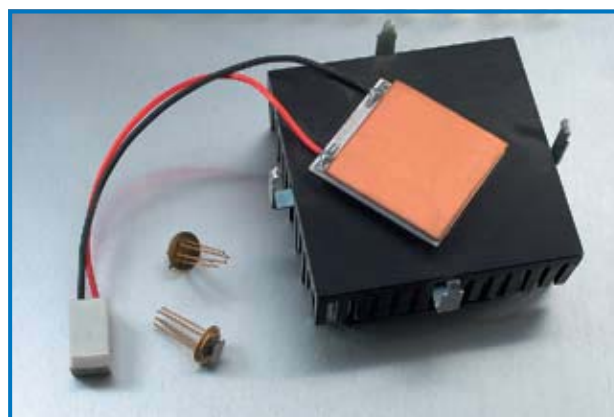

Additional options

Description	Notation (*)	Note
processing temperature up to 120 °C, max assembly temperature = 130 °C	HT(120)	assembly solder with $T_m = 139$ °C
processing temperature up to 150 °C, max assembly temperature = 170 °C	HT(150)	assembly solder Pb-Sn with $T_m = 183$ °C
processing temperature up to 200 °C, max assembly temperature = 220 °C	HT(200)	assembly solder with $T_m = 232$ °C
special version for operation under conditions of temperature cycling	C	$> 10^5$ cycles +40°C/+90°C
height tolerance = ± 0.025 mm and parallelism 0.02 mm	L2	
height tolerance = ± 0.015 mm and parallelism 0.01 mm	L3	
metallization of cold (mc) and (or) hot side of cooler with solder tinning (melting temperature = 95 °C, 117 °C, 139 °C, 183 °C)	mc95, mh95, mm117 etc.	
gold plating	mcAu, mhAu, mmAu	metallization Cu-Ni-Au
substrate material – aluminium nitride (AlN)	N	heat conductivity > 180 W/mK
sealant: epoxy, silicon, urethane or conformal coating	E, S, U, Cc	
non-standard pin orientation		
type and length of wires by customer's requirement		
connection to arrais		
connectors crimping		
soldering on cold or hot heatsink, packaging or cold block		

(*) the notations shown are used to notate additional options in cooler name

Examples:

1. FROST-72 HT (150) – thermoelectric cooler FROST-72, with max processing temperature 150 °C, with substrate material of aluminium oxide.

2. DRIFT-0,8HT (200) mmAu N – thermoelectric cooler DRIFT-0,8 with max processing temperature 200 °C, with substrate material of aluminium nitride. Cold and hot ends are metallized with golden coating.



Applied as mini and microcoolers in the systems of thermo stabilization of microchips, semiconductor lasers, photodetectors and other temperature sensitive elements and components of electronic devices.

Main fields of application

Microwave techniques

- cooling of the input stages of the high sensitive receivers and amplifiers
- thermostabilization of the parametric devices

Optoelectronics

- Contact cooling of semiconductor lasers, infrared detectors, CCD-matrix
- miniconditioners for photomultipliers

Special computer engineering

- microprocessor coolers

Coolers for radio electronics

Type	I _{max}	Q _{max}	U _{max}	ΔT _{max}	R _{ac}	Dimensions (mm)					Orientatation of outputs	
	(Amps)	(Watts)	(Volts)	(K)	(Ohm)	A	B	C	D	H	short side	long side
TB-8-0.45-1.3	0.7	0.4	1.0	67	1.20	3.4	3.4	5.0	3.4	2.3		
TB-12-0.45-1.3	0.7	0.6	1.4	67	1.80	5.0	3.4	5.0	5.0	2.3		
TB-18-0.45-1.3	0.7	0.9	2.2	67	2.80	5.0	5.0	6.6	5.0	2.3		
TB-32-0.45-1.3	0.7	1.7	3.9	67	5.00	6.6	6.6	8.3	6.6	2.3		
TB-66-0.45-1.3	0.7	3.5	8.0	67	10.00	9.1	9.9	11.5	9.1	2.3		
TB-7-0.6-1.5	1.1	0.6	0.9	69	0.59	4.3	4.3	4.3	4.3	3.25		
TB-11-0.6-1.5	1.1	0.9	1.4	69	0.91	9.0	4.0	4.0	9.0	3.25	+	
TB-17-0.6-1.5	1.1	1.4	2.1	69	1.50	6.3	6.3	6.3	6.3	3.25		
TB-31-0.6-1.5	1.1	2.6	3.8	69	2.55	8.0	8.0	8.0	8.0	3.25		
TB-35-0.6-1.5	1.1	3.0	4.3	69	3.10	12.0	6.0	6.0	12.0	3.25	+	+
TB-65-0.6-1.5	1.1	5.5	8.1	69	5.60	13.0	12.0	12.0	13.0	3.25		+
TB-7-0.6-1.2	1.4	0.7	0.9	69	0.51	4.3	4.3	4.3	4.3	2.95		
TB-11-0.6-1.2	1.4	1.2	1.4	69	0.75	9.0	4.0	4.0	9.0	2.95	+	
TB-17-0.6-1.2	1.4	1.8	2.1	69	1.20	6.3	6.3	6.3	6.3	2.95		
TB-31-0.6-1.2	1.4	3.3	3.8	69	2.05	8.0	8.0	8.0	8.0	2.95		
TB-35-0.6-1.2	1.4	3.7	4.3	69	2.40	12.0	6.0	6.0	12.0	2.95	+	+
TB-65-0.6-1.2	1.4	6.9	8.1	69	4.60	13.0	12.0	12.0	13.0	2.95		+
TB-7-0.6-1.0	1.7	0.9	0.9	69	0.39	4.3	4.3	4.3	4.3	2.75		
TB-11-0.6-1.0	1.7	1.4	1.4	69	0.62	9.0	4.0	4.0	9.0	2.75	+	
TB-17-0.6-1.0	1.7	2.2	2.1	69	0.95	6.3	6.3	6.3	6.3	2.75		
TB-31-0.6-1.0	1.7	3.9	3.8	69	1.70	8.0	8.0	8.0	8.0	2.75		
TB-35-0.6-1.0	1.7	4.4	4.3	69	2.08	12.0	6.0	6.0	12.0	2.75	+	+
TB-65-0.6-1.0	1.7	8.3	8.1	69	4.00	13.0	12.0	12.0	13.0	2.75		+
TB-7-0.6-0.8	2.1	1.1	0.9	68	0.34	4.3	4.3	4.3	4.3	2.55		
TB-17-0.6-0.8	2.1	2.6	2.1	68	0.76	6.3	6.3	6.3	6.3	2.55		
TB-31-0.6-0.8	2.1	4.8	3.8	68	1.40	8.0	8.0	8.0	8.0	2.55		
TB-35-0.6-0.8	2.1	5.4	4.3	68	1.70	12.0	6.0	6.0	12.0	2.55	+	+
TB-65-0.6-0.8	2.1	10.1	8.0	68	3.00	13.0	12.0	12.0	13.0	2.55		+
TB-109-0.6-0.8	2.1	16.9	13.4	68	5.30	26.0	12.0	12.0	26.0	2.55	+	
TB-17-1.0-0.7	6.6	8.4	2.1	68	0.24	8.0	8.0	8.0	8.0	2.45		



Technological features:

According to RoHS directive requirements, the offered thermoelectric coolers do not contain lead or any other forbidden materials.



We also offer thermoelectric coolers installed or directly integrated into the standard — TO (TO3, TO8 etc.), HHL, DIL, butterfly or special bodies.

System of notation:

A universal abbreviation is used to notate single-stage coolers: **TB-N-C-h**, where:

- TB** — product contraction — thermoelectric battery (cooler);
 - N** — number of thermocouples in the cooler;
 - C** — length of the rib of the thermoelectric element basis (in millimeters);
 - h** — height of the thermoelectric element (in millimeters)
- For example, in the module TB-109-0.6-0.8: 109 thermocouples (218 thermoelectric elements), every element has the cross-section of 0.6×0.6 mm and is 0.8 mm high.

Standard terms of delivery

- substrate material — alumina (BK-96)
- height tolerance ± 0.15 mm
- parallelism 0.15 mm
- cable length 50 mm
- pin orientation (for rectangular modules) — to the long side
- processing temperature up to 80 °C, maximal assembly temperature 120 °C (assembly solder $T_m = 139$ °C)

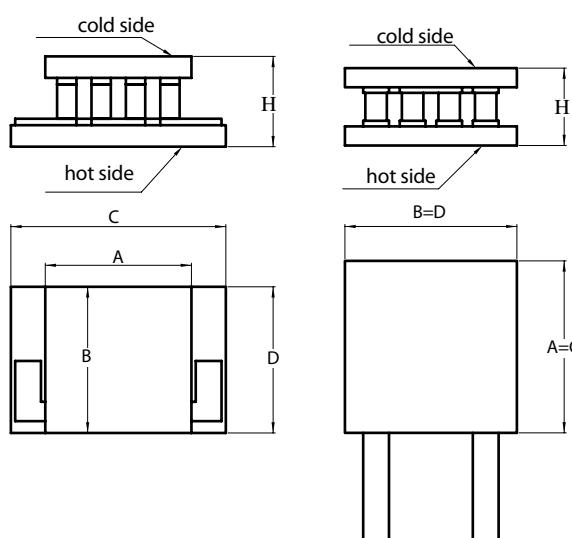
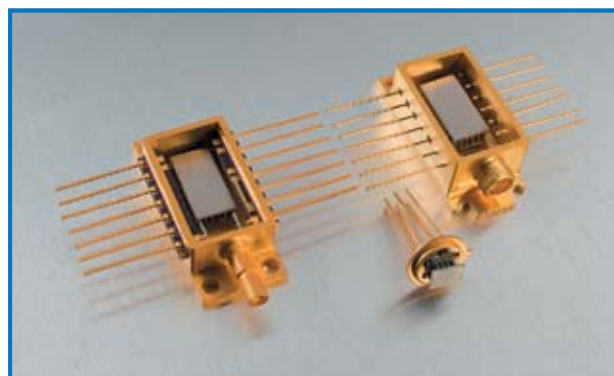

Additional options

Description	Notation (*)	Note
processing temperature up to 120 °C, max assembly temperature = 130 °C	HT(120)	assembly solder with $T_m = 139$ °C
processing temperature up to 150 °C, max assembly temperature = 170 °C	HT(150)	assembly solder Pb-Sn with $T_m = 183$ °C
processing temperature up to 200 °C, max assembly temperature = 220 °C	HT(200)	assembly solder with $T_m = 232$ °C
height tolerance = ± 0.05 mm and parallelism 0.03 mm	L1	
height tolerance = ± 0.025 mm and parallelism 0.02 mm	L2	
metallization of cold (mc) and (or) hot side of cooler with solder tinning (melting temperature = 95 °C, 117 °C, 139 °C, 183 °C)	mc95, mh95, mm117 etc.	
gold plating	mcAu, mhAu, mmAu	metallization Cu-Ni-Au
substrate material – aluminium nitride (AlN)	N	heat conductivity > 180 W/mK
sealant: epoxy, silicon, urethane or conformal coating	E, S, U, Cc	
non-standard pin orientation		
type and length of wires by customer's requirement		
soldering on cold or hot heatsink, packaging or cold block		

(*) the notates shown are used to notate additional options in cooler name
 For example, TB-109-0.6-0.8 HT(200) mmAu N denotes thermobattery TB-109-0.6-0.8 made on substrate material of aluminium nitride with processing temperature up to 200 °C, with metallization of both substrate material plates by golden coating.



Multistage thermoelectric coolers

Applied in deep chilling systems, refrigerators with a large temperature difference, cooling systems for scientific, research and special devices. Also used for cooling infrared photodetectors, X-ray detectors, etc.

Main fields of application:

- CCD-matrix and infrared photodetectors cooling
- cold cells and freezers
- thermostats
- scientific and laboratory equipment
- thermocalibrators
- step coolers
- different coolers and thermostabilizers of detectors
- night vision equipment

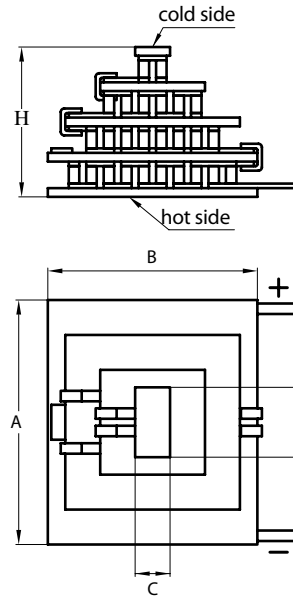

2-stage thermoelectric coolers

Type	I_{max}	Q_{max}	U_{max}	ΔT_{max}	Dimensions (mm)				
	(Amps)	(Watts)	(Volts)	(K)	A	B	C	D	H
TB-2-(11-4)-1.5	1.0	0.4	1.3	93	6.0	4.0	2.0	4.0	<6.7
TB-2-(11-4)-1.2	1.2	0.5	1.3	92	6.0	4.0	2.0	4.0	<6.1
TB-2-(11-4)-1.0	1.5	0.6	1.3	92	6.0	4.0	2.0	4.0	<5.7
TB-2-(17-4)-1.5	1.1	0.4	2.0	94	8.0	6.0	2.0	4.0	<6.7
TB-2-(17-4)-1.2	1.3	0.5	2.0	93	8.0	6.0	2.0	4.0	<6.1
TB-2-(17-4)-1.0	1.6	0.6	2.0	91	8.0	6.0	2.0	4.0	<5.7
TB-2-(31-8)-1.5	1.1	0.9	3.6	93	10.0	8.0	4.0	4.0	<6.7
TB-2-(31-8)-1.2	1.3	1.1	3.6	92	10.0	8.0	4.0	4.0	<6.1
TB-2-(31-8)-1.0	1.6	1.3	3.6	91	10.0	8.0	4.0	4.0	<5.7
TB-2-(31-12)-1.5	1.0	1.1	3.7	93	10.0	8.0	4.0	6.0	<6.7
TB-2-(31-12)-1.2	1.2	1.4	3.7	92	10.0	8.0	4.0	6.0	<6.1
TB-2-(31-12)-1.0	1.4	1.6	7.1	91	10.0	8.0	4.0	6.0	<5.7
TB-2-(59-18)-1.5	1.1	1.8	7.1	94	12.0	12.0	6.0	6.0	<6.7
TB-2-(59-18)-1.2	1.3	2.2	7.1	93	12.0	12.0	6.0	6.0	<6.1
TB-2-(59-18)-1.0	1.5	2.6	7.0	92	12.0	12.0	6.0	6.0	<5.7
TB-2-(127-127)-1.3	2.8	16.1	15.4	83	30.0	30.0	30.0	30.0	<8.8
TB-2-(127-127)-1.15	5.8	34.0	15.4	84	40.0	40.0	40.0	40.0	<8.5
BULLFINCH	8.8	31.0	8.9	87	40.0	40.0	40.0	40.0	<7.5
TB-2-(199-199)-0.8	10.2	95.0	24.0	84	40.0	40.0	40.0	40.0	<6.8

Multistage thermoelectric coolers



System of notation:

A universal abbreviation is used to notate multi-stage coolers: **TB-n-(N1-N2-N3-N4)-h**, where:

TB — product contraction — thermoelectric battery (cooler);

n — number of stages in the cooler;

N1-N4 — number of thermocouples in the first, second, third and fourth stages of the thermoelectric cooler.

(N1-N2) is used for two-stage coolers, (N1-N2-N3) — for three-stage coolers and (N1-N2-N3-N4) — for four-stage coolers.

h — height of the thermoelectric element in the top stage (in millimeters)

For example, in the cooler TB-2-(11-4)-1.0: 2 stages, 11 couples in the first stage, 4 couples in the second stage, the height of the elements in the top stage is 1.0 mm.

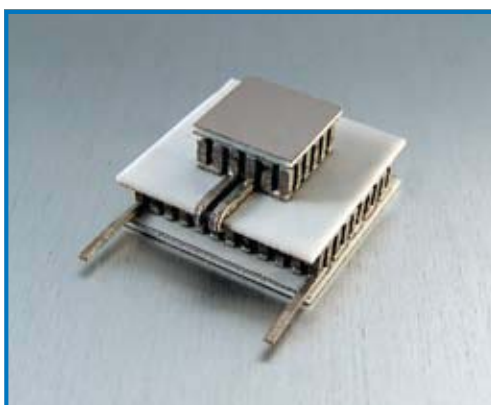
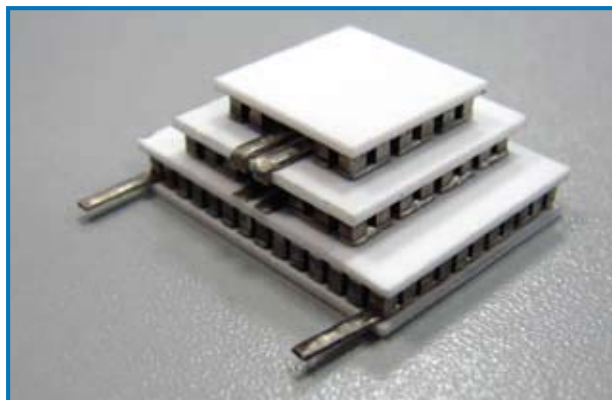

Technological features:

According to RoHS directive requirements, the produced thermoelectric modules do not contain lead or any other forbidden materials.



For the top stages an optimized thermoelectric material that allows us to reach the big value ΔT with a smaller amount of stages is used. This makes it possible to produce multistage modules with optimal dimensions and low power consumption.

We also offer thermoelectric coolers, installed or integrated in the standard — TO (TO3, TO8 etc.), HHL, DIL, butterfly or special bodies.

3-stage thermoelectric coolers

Type	I_{max}	Q_{max}	U_{max}	ΔT_{max}	Dimensions (mm)				
	(Amps)	(Watts)	(Volts)	(K)	A	B	C	D	H
TB-3-(31-11-4)-1.5	0.9	0.4	3.5	109	10.0	8.0	2.0	4.0	<9.3
TB-3-(31-11-4)-1.2	1.1	0.5	3.5	108	10.0	8.0	2.0	4.0	<8.4
TB-3-(31-11-4)-1.0	1.3	0.6	3.5	107	10.0	8.0	2.0	4.0	<7.8
TB-3-(59-17-4)-1.5	1	0.5	6.8	114	12.0	12.0	2.0	4.0	<9.3
TB-3-(59-17-4)-1.2	1.2	0.6	6.8	113	12.0	12.0	2.0	4.0	<8.4
TB-3-(59-17-4)-1.0	1.4	0.7	6.8	112	12.0	12.0	2.0	4.0	<7.8
TB-3-(83-18-4)-1.3	3.7	2.5	10	118	24.0	20.6	8.7	4.5	<10.8



Multistage thermoelectric coolers

Standard terms of delivery:

- substrate material — alumina (BK-96)
- height tolerance $\pm 0,35$ mm
- pin orientation (for rectangular coolers) — to the longer side
- processing temperature up to 80°C, maximal assembly temperature: 120°C (assembly solder $T_m = 139^\circ\text{C}$)



4-stage thermoelectric coolers

Type	I_{max}	Q_{max}	U_{max}	ΔT_{max}	Dimensions (mm)				
	(Amps)	(Watts)	(Volts)	(K)	A	B	C	D	H
TB-4-(59-31-11-4)-1.5	0.8	0.4	6.9	118	12.0	12.0	2.0	4.0	<12.2
TB-4-(59-31-11-4)-1.2	1	0.5	6.9	117	12.0	12.0	2.0	4.0	<11.0
TB-4-(59-31-11-4)-1.0	1.1	0.6	6.9	116	12.0	12.0	2.0	4.0	<10.2
TB-4-(83-18-4-1)-1.3	3.7	0.8	10	138	24.0	20.6	4.5	2.4	<13.6
TB-4-(127-71-31-17)-1.65	6.8	14.8	14.1	107	48.0	48.0	22.0	22.0	<15.0



Multistage thermoelectric coolers

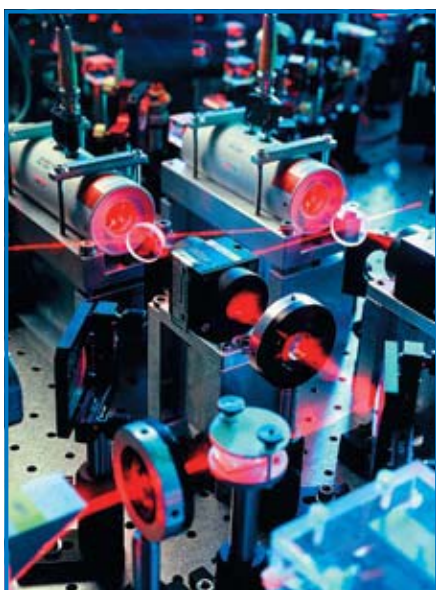

Additional options

Description	Notation (*)	Note
processing temperature up to 120 °C, max assembly temperature = 130 °C	HT(120)	assembly solder with Tm = 139 °C
processing temperature up to 150 °C, max assembly temperature = 170 °C	HT(150)	assembly solder Pb-Sn with Tm = 183 °C
processing temperature up to 200 °C, max assembly temperature = 220 °C	HT(200)	assembly solder with Tm = 232 °C
height tolerance = ± 0.05 mm	L1	
height tolerance = ± 0.025 mm	L2	
metallization of cold (mc) and (or) hot side of cooler with solder tinning (melting temperature = 95 °C, 117 °C, 139 °C, 183 °C)	mc95, mh95, mm117 etc.	
gold plating	mcAu, mhAu, mmAu	metallization Cu-Ni-Au
substrate material – aluminium nitride (AlN)	N	heat conductivity > 180 W/mK
sealant: epoxy, silicon, urethane or conformal coating	E, S, U, C	
non-standard pin orientation		
type and length of wires by customer's requirement		
non-standard height of cooler		
soldering on cold or hot heatsink, packaging or cold block		

(*) the notates shown are used to notate additional options in cooler name

For example, TB-2-(11-4)-1.0 HT (200) mmAu N denotes two-stage thermoelectric cooler with max processing temperature 200 °C, with substrate material of aluminium nitride. Cold and hot sides are metallized with golden coating.



Coolers for domestic refrigerating devices

Meant to be used in domestic devices, oriented towards mass consumer and produced in large quantities.

Main fields of application:

- portable automobile refrigerators and picnic boxes
- drinking water and tonic coolers
- thermoelectric refrigerators and minibars
- wine cabinets and beer coolers
- make-up mini refrigerators

Technological features:

According to RoHS directive requirements, the produced thermoelectric coolers do not contain lead or any other forbidden materials.



The high performance of the thermoelectric coolers, produced by KRYOTHERM allows the customers to increase the rate of cooling and reach a larger temperature difference in relation to the environment. Thermoelectric coolers are optimized for source voltage 12 V and perform high cooling power at low power consumption.

Up-to-date technologies used by KRYOTHERM to produce thermoelectric elements and assembly thermoelectric coolers, make it possible to produce TECs in large quantities (more than 100 000 units per month) while achieving high quality at low cost.

Standard terms of delivery:

- substrate material — alumina (BK-96)
- height tolerance ± 0.05 mm
- parallelism 0.03 mm
- wire length 120 mm
- processing temperature up to 80°C (assembly solder $T_m = 139^\circ\text{C}$)

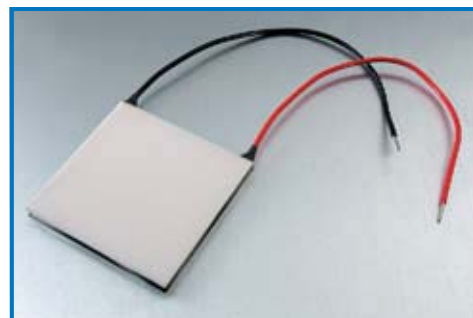

Thermoelectric coolers of LCB series

Type	I_{max}	Q_{max}	U_{max}	ΔT_{max}	R_{ac}	Dimensions (mm)				
	(Amps)	(Watts)	(Volts)	(K)	(Ohm)	A	B	C	D	H
LCB-127-1.0-1.3	3.6	36.0	16.1	71	3.20	30.0	30.0	30.0	30.0	3.6
LCB-127-1.4-1.5	6.1	61.0	16.1	71	2.05	40.0	40.0	40.0	40.0	3.9
LCB-127-1.4-1.15	8.0	80.0	16.1	71	1.50	40.0	40.0	40.0	40.0	3.4
LCB-127-1.0-0.8	5.8	56.0	15.7	69	2.00	40.0	40.0	40.0	40.0	3.2
LCB-127-1.4-2.5	3.7	37.4	16.3	72	3.2	40.0	40.0	40.0	40.0	4.8

Coolers for domestic refrigerating devices



System of notation:

A universal abbreviation is used to notate thermoelectric coolers: **LCB-N-C-h**, where:

- LCB** — series notation: low-cost thermoelectric battery for mass consumption;
- N** — number of thermocouples in the cooler;
- C** — length of the rib of the thermoelectric element basis (in millimeters);
- h** — height of the thermoelectric element (in millimeters)

For example, in the module LCB-127-1.0-1.3: 127 thermoelectric couples (256 thermoelectric elements), every element has the cross-section of 1.0x1.0 mm and is 1.3 mm high.

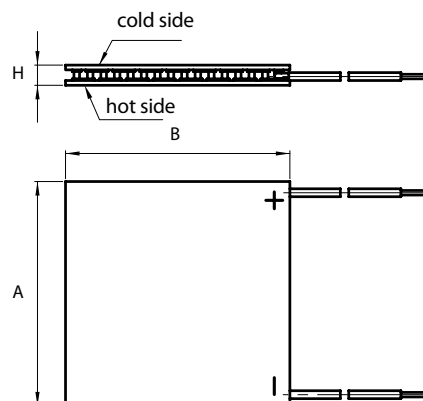

Additional options

Description	Notation (*)	Note
processing temperature up to 120 °C	HT (120)	assembly solder with $T_m = 139\text{ °C}$
processing temperature up to 150 °C,	HT (150)	assembly solder Pb-Sn with $T_m = 183\text{ °C}$
sealant: epoxy or silicon coating	E, S	
type and length of wires by customer's requirement		

(*) the notations shown are used to notate additional options in cooler name
 For example, LCB-127-1.4-1.5-HT (150) denotes thermoelectric cooler with max processing temperature 150 °C, with substrate material of aluminium oxide.





Special thermoelectric coolers

Used in cases, making special requirements towards TEC's properties and construction

Examples of special operational conditions:

- high vacuum ($< 10^{-6}$)
- large mechanical loads (peak acceleration up to 1500 g)

special requirements towards TECs characteristics:

- TEC height lower than 1.5 mm
- high cooling rate > 10 K/sec
- high cooling power density > 20 W/sm², etc.

For the mentioned cases KRYOTHERM offers a special list of thermoelectric coolers.

The mentioned technologies are used to produce coolers for:

- space application
- optoelectronics and telecommunications
- medicine
- scientific research.

KRYOTHERM produces the majority of TECs to fit these aims on special demands.

As an example, the table lists the characteristics of some of the special TECs.

Technological features:

During the production of these modules substrate material AlN is used with thermal conductivity > 180 W/mK or superfine substrate material Al₂O₃ (100%), special thermoelectric elements with low height and high mechanical solidity and thermal bridges with small intercell gaps and small contact heat resistance.

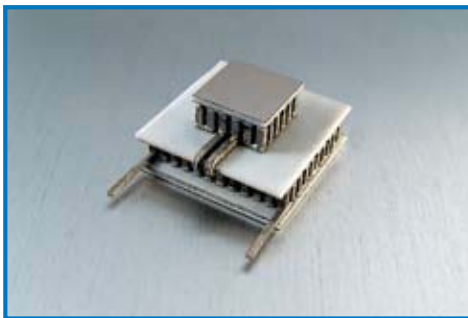

Versions of performance:

- substrate material — AlN or Al₂O₃ (BK-100)
- gold plating or solder tinning
- assembly solder from 139°C to 232°C (max assembly temperature: from 95°C to 220°C)
- mounting on cold or heat radiator, body or cold block.

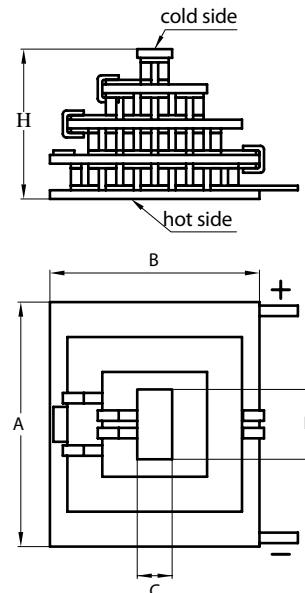

Multistage coolers

Model	Imax	Qmax	Umax	ΔTmax	Dimensions (mm)				
	(Amps)	(Watts)	(Volts)	(K)	A	B	C	D	H
TB-2-(15-2)-0.55	2.4	0.6	2.2	103	5.6	5.6	2.4	2.4	2.3
TB-2-(39-38)-1.1	2.3	5.0	5.4	89	19.5	14.5	19.5	14.5	6.0
TB-3-(59-17-5)-1.0	1.3	0.8	6.4	108	12.0	12.0	4.0	5.0	<8.7
TB-4-(199-199-63-17)-1.4	2.15+14.2*	7.3	19.0+10.1*	138	40.0	40.0	15.0	15.0	14.0

* Operation mode by separate power supply of stages.

Special thermoelectric coolers

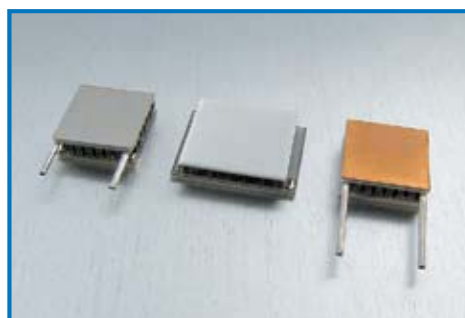
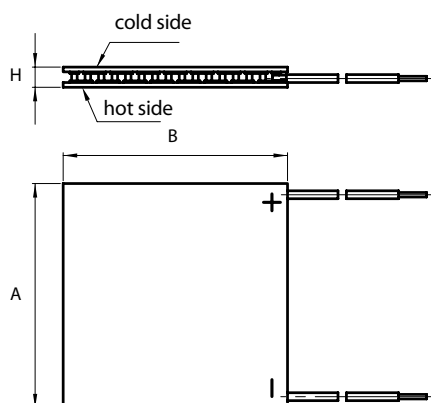

Microcoolers

Model	I_{max}	Q_{max}	U_{max}	ΔT_{max}	R_{ac}	Dimensions (mm)				
	(Amps)	(Watts)	(Volts)	(K)	(Ohm)	A	B	C	D	H
TB-19-0.45-0.6	1.5	1.95	2.3	68	1.1	6.6	3.8	5.0	3.8	1.2
TB-31-0.6-0.8	2.1	4.8	3.8	68	1.40	6.2	12.0	6.2	10.2	2.2
TB-35-0.6-0.8	2.1	5.5	4.3	68	1.7	6.0	12.0	6.0	12.0	1.85

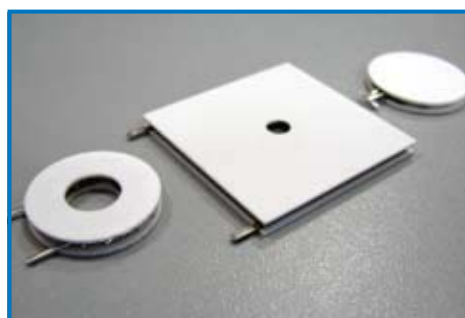
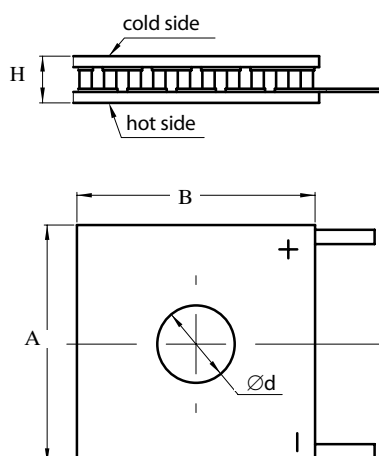

Coolers with a hole

Model	I_{max}	Q_{max}	U_{max}	ΔT_{max}	R	Dimensions (mm)			
	(Amps)	(Watts)	(Volts)	(K)	(Ohm)	A	B	H	d
TB-53-0.5-0.6CH	1.96	7.6	6.5	69	2.50	12.0	12.0	1.6	5.0



Generating thermoelectric modules

Nations the world over are actively searching for alternative, clean energy sources. Using the thermoelectric modules to generate electro energy is becoming vital, valid choice. Interest in energy sources such as thermoelectric generating modules is warming because of the latest achievements in the sphere of thermoelectric technology and constructions.

Using the generating thermoelectric modules (TGM), produced by KRYOTHERM, makes it possible to provide generation of the electro energy with up to 10 W with direct current voltage up to 6 V with one TGM with a temperature difference of 100 °C.

Main TGM application:

- utilization of worthless heat at transport installations (automobiles, ships);
- autonomic supply of energy to electronic blocks for water boilers and disposal plants;
- cathodic protection of the oil and gas pipelines;
- conversion of natural heat resources — geothermal waters, etc into electric energy;
- autonomic power supply of low-power electric devices.

Application recommendations:

1. Generating modules (TGM) must be installed on flat surface. This requirement is especially vital for the cold side of TGM. The purity of surface processing on which TGM is installed must be better than 20 microns.
2. The pressing force must be not less than 12-15 kg/cm²
3. Temperature of the hot seam shall not exceed 200 °C

Attention! During the exploitation of TGM with the decrease of electric load an increase of the hot seam temperature up to 5% off the difference between hot and cold sides of the module can follow.

Performance Data

Type	Geometrical dimensions, mm			Cold end = 50 0C Hot end = 150 0C					
				Internal resistance	Heat resistance	Voltage	Current	Power	Efficiency
	A	B	H	Ohm	K/W	V	A	W	%
TGM-127-1.0-0.8	30	30	3.1	2.41	1.40	1.83	0.76	1.38	2.3
TGM-127-1.0-1.3	30	30	3.6	3.92	2.27	2.18	0.56	1.21	2.7
TGM-127-1.0-2.5	30	30	4.3	7.53	4.36	2.55	0.34	0.86	3.2
TGM-127-1.4-1.5	40	40	3.9	2.46	1.43	2.25	0.91	2.05	2.8
TGM-127-1.4-2.5	40	40	4.8	3.84	2.23	2.50	0.65	1.63	3.2
TGM-199-1.4-0.8	40	40	3.2	1.93	0.45	2.19	1.14	2.49	1.8
TGM-199-1.4-1.2	40	40	3.6	2.89	0.68	2.69	0.93	2.50	2.2
TGM-199-1.4-1.5	40	40	3.9	3.85	0.91	3.03	0.79	2.39	2.4
TGM-287-1.0-1.3	40	40	3.6	8.85	1.00	4.54	0.51	2.33	2.5
TGM-287-1.0-1.5	40	40	3.8	10.20	1.16	4.77	0.47	2.23	2.7
TGM-287-1.0-2.5	40	40	4.8	17.00	1.93	5.49	0.32	1.77	3.1

Generating thermoelectric modules



System of notation



A universal abbreviation is used to notate generating modules: **TGM-N-C-h**, where:

- TGM** — product contraction — generating thermoelectric module;
- N** — number of thermocouples in the module;
- C** — length of the rib of the thermoelectric element basis (in millimeters);
- h** — height of the thermoelectric element (in millimeters)

For example, in the module TGM-127-1.0-2.5: 127 thermocouples (254 thermoelectric elements), every element has the cross-section of 1.0×1.0 mm and is 2.5 mm high.

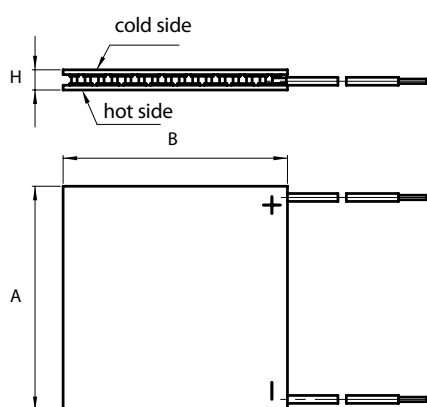

Performance Data

Type	Cold end = 100 0C Hot end = 200 0C					
	Internal resistance	Heat resistance	Voltage	Current	Power	Efficiency
	Ohm	K/W	V	A	W	%
TGM-127-1.0-0.8	2.51	1.36	1.73	0.69	1.19	2.0
TGM-127-1.0-1.3	4.07	2.21	2.07	0.51	1.05	2.4
TGM-127-1.0-2.5	7.84	4.26	2.43	0.31	0.75	2.8
TGM-127-1.4-1.5	2.56	1.39	2.13	0.83	1.78	2.4
TGM-127-1.4-2.5	4.00	2.17	2.38	0.60	1.42	2.7
TGM-199-1.4-0.8	2.00	0.44	2.07	1.03	2.14	1.5
TGM-199-1.4-1.2	3.01	0.67	2.55	0.85	2.16	1.9
TGM-199-1.4-1.5	4.01	0.89	2.88	0.72	2.06	2.1
TGM-287-1.0-1.3	9.21	0.98	4.30	0.47	2.01	2.2
TGM-287-1.0-1.5	10.60	1.13	4.52	0.43	1.93	2.3
TGM-287-1.0-2.5	17.70	1.88	5.22	0.29	1.54	2.6



Thermoelectric cooling assemblies

Apart from thermoelectric modules KRYOTHERM also produces different types of thermoelectric cooling assemblies.

Thermoelectric cooling assembly is a device, produced like several heat-exchange devices bound together with thermoelectric coolers between them.

Sphere of application of the thermoelectric assemblies is very wide. They can be used for production of refrigerators, air conditioners, systems of electronic devices cooling, etc. Assemblies are optimized for 12, 24 and 48 V supply voltage that makes it possible to plug in them to the power sources of automobile, railroad and water transport.

The thermoelectric assemblies of "air-to-air" type, produced by KRYOTHERM, include fans apart from hot and cold heat sinks. Using heat sinks with an advanced surface makes it possible to transmit heat from the cooling object to the cold side of the module and from the hot side of the module into the environment with minimal temperature loss. Heat sink blowing by means of fans makes this process more effective. Heat insulation, installed between the heat sinks, hinders the reverse transfer of heat to the cooling object.



Each KRYOTHERM thermoelectric assembly has holes for mounting and switching plane for power supply. A temperature sensor and temperature controller installation on the assembly is available as an extra option.



Thermoelectric cooling assemblies of air-to-air type

Name	I operating	U operating	Q operating	Q max	Dimensions in mm			Weight kg
	(Amps)	(Volts)	(Watts)	(Watts)	length	width	height	
60-24-AA	3.2	24.0	45.0	106.0	240.0	150.2	155.0	2.9
60-12-AA	6.4	12.0	45.0	106.0	240.0	150.2	155.0	2.9
120-24-AA	5.1	24.0	75.0	195.0	320.0	150.2	155.0	3.8
120-12-AA	10.2	12.0	75.0	195.0	320.0	150.2	155.0	3.8
180-24-AA	5.8	24.0	85.0	180.0	480.0	150.2	155.0	5.7
380-24-AA	10.4	24.0	200.0	380.0	252.0	200.0	210.0	6.4

Thermoelectric cooling assembly of liquid-to-liquid type

400LT	24.5	24.0	400.0	600.0	247.0	49.0	204.0	5
-------	------	------	-------	-------	-------	------	-------	---

COMPANY PROFILE





Company profile



KRYOTHERM was founded in 1992 on the basis of a largest Soviet research institute engaged in development of thermoelectric coolers and subsystems for military and aerospace industries. A high production capacity, flexibility of technological equipment, the use of modern technologies, and professional management have made KRYOTHERM a reliable provider of thermoelectric coolers and subsystems to more than 1000 companies all over the world. Our products have found application in industrial and consumer coolers, medical and electronic instruments, telecommunications and radioelectronic equipment. They are also used in aerospace and special-purpose devices. At present the staff of the company is 180 persons, including 12 PhDs.



The activities of KRYOTHERM rely on the strategy directed towards providing safe, reliable, highly effective products, best service and full engineering and technical support to our customers.

We possess an overall technological cycle for production of thermoelectric cooling and generating modules: synthesis of thermoelectrical materials, their cutting into pellets, deposition of antidiffusion coatings, cooler assembly, and sealing. The quality system used by the Company includes continuous control of all the technological stages and testing of the finished products.

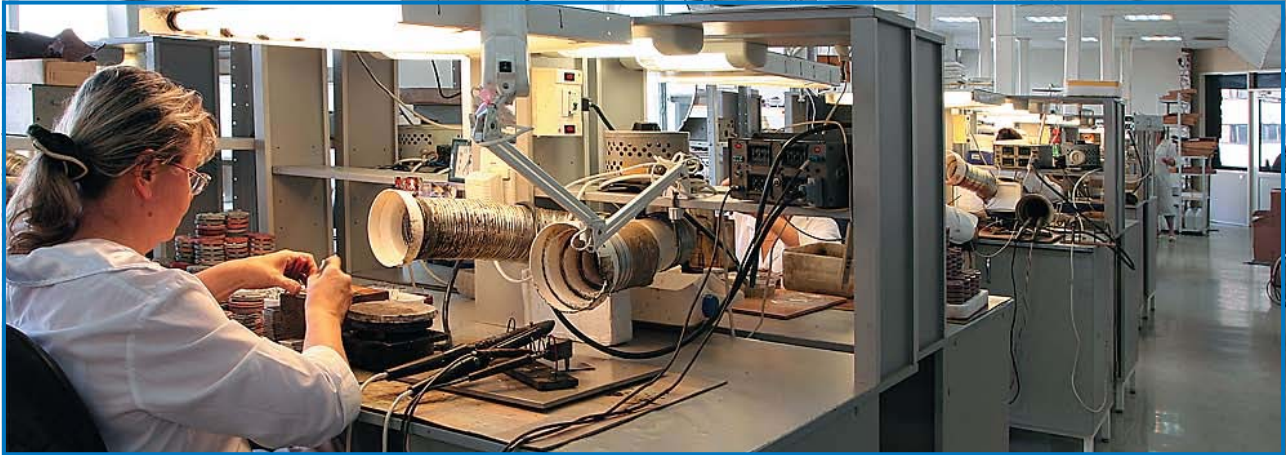

Our company continuously expands and improves the range of products. At present we fabricate more than 250 types of thermoelectric coolers. Taking into account additional options, the total nomenclature includes several thousands of items and is able to satisfy the exacting needs of our customers. At a customer's request, KRYOTHERM can develop and fabricate a pilot batch of a new type of coolers during 60 days.

One of the directions of our activities is development and fabrication of thermoelectric systems at the request of our customers. Such an approach allows us to offer the most efficient solutions based on our 30-year experience in thermoelectricity.

We continuously improve the quality and parameters of our products, expand their range, and offer favorable conditions for cooperation. Technical parameters and high reliability of the thermoelectric coolers produced by KRYOTHERM fully correspond to world-class standards.

For information about our company visit our web site at <http://www.kryotherm.ru>





Quality control system



Special attention is paid by KRYOTHEM to control of quality and reliability of our thermoelectric coolers.

Our company has an up-to-date quality system that involves careful input control of materials and components, control of manufacturing process, and tests of finished products.

Steady improvement and development of process control methods is, in our opinion, a necessary condition for fabrication of high-quality products to meet the ever-increasing demands of our customers.

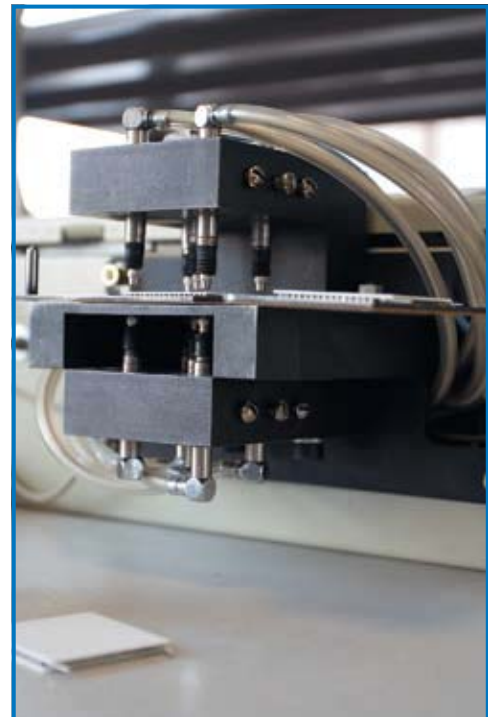

A distinctive feature of KRYOTHERM is an individual approach to each customer's order. We offer a wide range of products for different applications and confirm the high quality of our products by multiple tests carried out in accordance with the Quality System of our Company. Diverse measuring and test instruments are used for the tests.



The tests are classified as:

1. Acceptance
2. Periodical
3. Reliability
4. Standardized

Acceptance tests are aimed at control of the conformity of coolers to KRYOTHERM standards and customer's specifications. 100% of the coolers produced are subjected to this test.

Acceptance tests include:

1. Control of geometrical dimensions
2. Control of electrophysical parameters of coolers: resistance and thermoelectric figure of merit
3. Visual control
4. Check for compliance with the customer's specifications.

Periodical tests are aimed at control of the technological processes used for TEC manufacturing. Periodical tests are performed on 2–3 types of coolers at least once a 1/2 year. Two coolers of each type that have passed the acceptance tests in full volume are subjected to this test.

In the case the existing technological processes are modified or new processes are introduced, unscheduled periodical tests of the products manufactured by using the new or modified technology are carried out. Periodical tests conform to the requirements of MIL-STD-883 and GOST 20.57.406, 20.57.406-81, 15150.

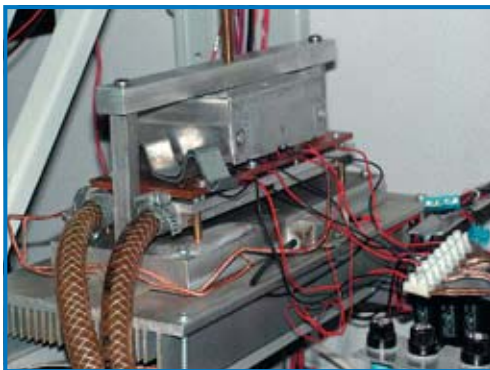



Periodical tests include:

1. Strength tests under sinusoidal vibration (MIL-STD-883, method 2002)
2. Strength tests under single mechanical shocks (MIL-STD-883, method 2007)
3. Shear strength tests (MIL-STD-883, method 2019)
4. Transportation tests (GOST 15150)
5. Effect of elevated humidity — for sealed coolers ($T = +27^{\circ}\text{C}$, relative humidity is 100%)
6. Cyclic variation of ambient temperature (MIL-STD-883, method 1010)
6. Life-time tests (1000 h, $I = 0.75I_{\text{max}}$, $T_h = 27 \pm 10^{\circ}\text{C}$)
7. Temperature cycling (test $+40^{\circ}\text{C}/+90^{\circ}\text{C}$ with change of current polarity, not less than 10^4 cycles)
8. Control of insulation resistance of TEC

Reliability tests are performed for the TECs on which more strict requirements to operational reliability are specified.

Reliability tests include:

1. Strict temperature cycling (test $0^{\circ}\text{C}/+100^{\circ}\text{C}$ with current polarity reversal, not less than 10^3 cycles)
2. Temperature cycling (test $+40^{\circ}\text{C}/+90^{\circ}\text{C}$ with current polarity reversal, not less than 2×10^4 cycles for standard TEC and 10^5 cycles for the TEC to be operated under thermocycling conditions)
3. High temperature storage ($+85^{\circ}\text{C}$)
4. Low temperature storage (-40°C)
5. Cyclic variation of ambient temperature (MIL-STD-883, method 1010)
6. Storage at high humidity — for sealed coolers ($+85^{\circ}\text{C}$, relative humidity 100%)

Standardized tests are aimed at estimation of the effectiveness and advisability of introducing changes in the methods of TECs production and the using new materials and components. The content of tests is determined by the type of supposed changes.

All inspections and tests of TECs, unless otherwise specified, are conducted under normal climatic conditions: air temperature — $(25 \pm 10^{\circ}\text{C})$, relative humidity of air — 45–80%, atmospheric pressure — 84–106.7 kPa (630–800 mmHg). Additional tests can be performed at a special customer's request. The content and parameters of these tests are agreed with the customer and depend on the anticipated TEC application.

Detailed information on tests with description of the methods and also protocols with the results of tests are given on our web site at <http://www.kryotherm.ru>



TECHNICAL SUPPORT





1. TEC thickness

The base height of each type of KRYOTHERM TECs is given in the company product catalogue. The overall TEC thickness ranges within the base height ± 0.15 mm unless otherwise specified. The standard height variation within one production lot does not exceed ± 0.05 mm. KRYOTHERM common parallelism of the produced TEC's is 0.03 mm. (*)

If several TEC's are to be installed in one thermoelectric cooler, they are to be manufactured in accordance with such strict requirements to the TEC's height tolerance and parallelism as ± 0.025 mm and 0.02 mm respectively. Another production option available with Kryotherm is ± 15 micron tolerance on TEC base height and 10 micron parallelism when so specified. At request TECs can be produced with the height different from the one given in the product catalogue.



(*) KRYOTHERM standard height tolerance on miniature and metallized TEC's within one production lot is ± 0.15 mm. Kryotherm standard parallelism of its miniature and metallized TEC's is 0.15 mm.

2. Reliability of Thermoelectric Coolers

Reliability is one of the major criterion of thermoelectric module (TEC) selection. TEC's are considered to be highly reliable components due to their solid-state construction. However, KRYOTHERM experience in thermoelectrics made it possible to highlight the following main causes of premature TEC failure:

- TEC improper operation and its faulty mounting, in the first place, which leads to TEC mechanical failure;
- TEC improper installation, which provides poor thermal contact between TEC's hot side and heat exchanger;
- Insufficient dissipation of heat generated on TEC's hot side or increased voltage supply, which leads to TEC's overheating during its operation;
- Fast temperature alteration of TEC's cold and (or) hot side on wide scale (thermal cycling).

General instructions on how to properly install KRYOTHERM TEC's are given below. We strongly recommend you to go over the TEC Mounting Instructions especially if it is your first experience in doing so. If you choose the best fitted TEC's for you application or design/ calculate a thermoelectric cooling assembly, it is highly important to take into account

For applications requiring strict temperature cycling KRYOTHERM produces special modules — indicated by a "C" index in their name — with mechanical design that allows our customers to minimize the destructive effects of periodic mechanical stresses that occur with temperature cycling. Such modules, under other equal conditions, sustain the number of temperature cycles by an order of magnitude larger in comparison with standard TECs.



the processing temperature on TEC's hot side, which should not exceed the maximum processing temperature given in the TEC's specification. Otherwise, this may result in intense degradation changes in semiconductor material parameters or cause TEC failure. Kryotherm off-the-shelf TEC's maximum processing temperature of 80°C, 120°C, 150°C, and 200°C. TECs with processing temperature of 120°C, 150°C and 200°C have additional index HT (120), HT (150) and HT (200), respectively. For applications requiring strict temperature cycling KRYOTHERM produces special modules — indicated by a "C" index in their name — with mechanical design that allows our customers to minimize the destructive effects of periodic mechanical stresses that occur with temperature cycling. Such modules, under other equal conditions, sustain the number of temperature cycles by an order of magnitude larger in comparison with standard TECs. The Mean Time Between Failures (MTBFs) for KRYOTHERM TEC's is 200,000 hours minimum at room temperature. It is recommended, however, to design a thermoelectric assembly in such a way as to use the lowest possible temperature on TEC's hot side to provide the maximum reliability of the assembly.

3. Mechanical Properties of Coolers

According to specifications used by KRYOTHERM Company during production of its products, thermoelectric coolers do not change their properties under the following conditions:

- sinusoidal vibration with frequency ranging from 20 Hz to 2,000 Hz, with acceleration amplitude of 20 g along three axes;
- periodic applied shocks with maximum acceleration up to 15 g and duration of 2–6 ms;
- single applied shock with maximum acceleration up to 500 g and duration of 1–2 ms along three axes;
- action of shear in accordance with MIL-STD-883 (method 219) standard.

For operation under specific conditions (military equipment, space systems) where substantial application of shocks is possible (instantaneous mechanical forces, strains, vibrations, etc.) we recommend to use special thermoelectric coolers for production of which original design solutions are used in order to provide for cooler trouble-free operation. KRYOTHERM has 30 years' experience of solution of such kind of tasks confirmed my trouble-free operation of coolers produced by KRYOTHERM under various extreme conditions.

4. Wires

KRYOTHERM tends to supply TEC's with attached lead wires to facilitate TEC's installation and power supply connection. Wire gauge and length are to be specified by our customers. The minimum wire length is 20 mm. The standard tolerance on stripping and pre-tinning of loose ends of lead wires is $\pm 1,0$ mm. KRYOTHERM standard tolerance on wire length is $\pm 2\%$ at wire length exceeding 50 mm, and ± 1 mm for shorter wires. KRYOTHERM TEC's with protruding outer tabs (electrodes) are equipped with colour shrink tubes to electrically isolate the soldering joint of wire attachment to TEC's outer tabs. Much attention and care should be paid if lead wire attachment is done outside KRYOTHERM factory.

It is highly important to use Bi-Sn solder with 139°C melting temperature for for standard and HT (120) coolers and POS-61 solder — for high-temperature HT (150) coolers and tin-antimony solder for high-temperature HT (200) coolers.

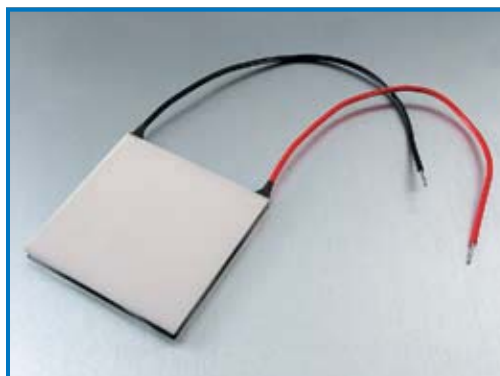

5. Metallized Coolers

KRYOTHERM metallized TECs make up one of the supply options. Metallized TECs are not subject to lapping. They are solder-mounted onto heat sinks or heat exchangers. TEC's metallized external surfaces of the substrate material plates can be coated with 95°C solder to ease TEC's soldering procedure. On special request the solder with melting temperature of

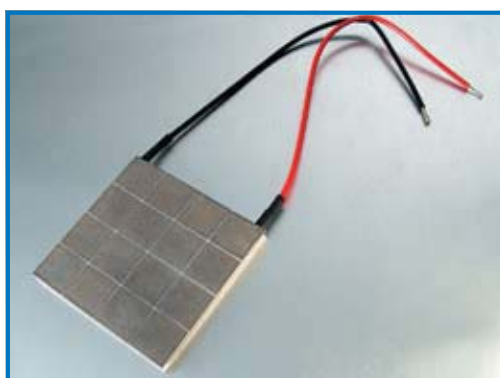

117°C can be used for standard coolers, and for HT (150) coolers — with 139°C. Coolers with processing temperature up to 200°C can be also tinned with solder having a melting temperature of 183°C. KRYOTHERM gold-coated metallized TEC's are specifically produced for such applications as telecommunication industry when TEC's are to be non-flux soldered.

6. TEC Moisture Protection

To protect TEC's from moisture and condensation, we suggest heading for the sealing option when KRYOTHERM TECs are sealed along the perimeter with silicone, epoxy or urethane sealant — they are shown by S, E, U indices in the name of thermoelectric cooler. The sealing techniques employed and up-to-date sealing materials make it possible to exclude the reverse heat transfer (i.e. the heat transfer from TEC's hot side



to its cold side) that appears when the sealant is being applied. The reduction in TEC's ΔT_{max} should not be more than 1–1.5°C. It is highly recommended not to seal TEC's yourself since this can lead to unintentional TEC damage. KRYOTHERM recommends strongly to its customers not to seal their coolers by their own efforts. Otherwise, KRYOTHERM do not bear any responsibility whatsoever as to the TEC's performance and their possible damage.

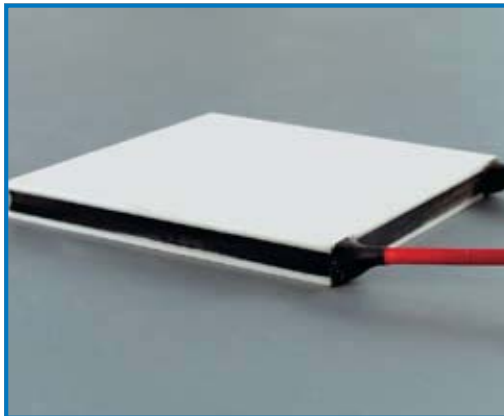

7. TEC Mounting Instructions

Please follow the given mounting instructions to attach KRYOTHERM polished TECs to a thermoelectric cooling assembly, which consists of hot heat sink, TEC, and cooled plate (the same mounting steps are applicable for other cases as well).

1. Prepare the surfaces of heatsink and plate. For this it is required to grind the surfaces of heatsink and plate providing for flatness of at least 0.035 mm (25 micron) on the linear dimension of TEC being installed. In order to prevent bending and distortion of heatsink and plate during assembly, the holes for tightening screws shall be arranged as close to the thermoelectric cooler as possible. Moreover, it is advisable that the bolt holes are arranged on the line of stiffening ribs of heatsink.
2. Apply thin and uniform layer of heat conducting paste (for example, KPT-8) on thermoelectric cooler and heatsink.

3. Mount thermoelectric cooler by its hot side to heatsink. Hot side of the cooler can be easily determined according to the rule outlined under the title "Connecting to Power Supply Unit". Thoroughly with uniform effort grind in the cooler to heatsink surface till obvious resistance to cooler movements appears. Remove excessive paste appearing on the cooler edges.
4. Perform operation outlined in p.p. 2–3 for cooler cold side and plate being cooled. In this case it is required to move the plate slightly along the cooler cold side.
5. Tighten the hot heatsink and the plate to be cooled to each other using heat insulating bushes. The material recommended for production of heat insulating bushes is polycapromide (caprolon). Tighten the assembly cooler with extreme care turning the tightening screws one after another in several steps. In case the assembly cooler consisting of several coolers is being installed, heatsink

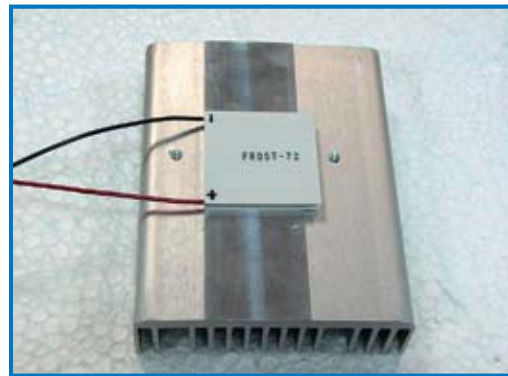

and plate should be tightened beginning from the screw being the nearest to the centre of assembly cooler. During the assembly gradually tighten each screw checking if possible the contact of the cooler with the plane of heatsink and plate.

Note: KRYOTHERM Company recommends the following values of mounting force (P_m) during assembly of non-metallized TECs:

Cooler type	P_m
Microcoolers	2–6 kg/cm ²
Standard single-stage coolers	5–12 kg/cm ²
High-efficient single-stage coolers	8–12 kg/cm ²
Multistage coolers	3–10 kg/cm ²

Proper tightening torque for the screws can be calculated by the following formula:

$T = P_m \times S_m \times N_m \times K \times d / N$, where:

T — torque value for each screw;

P_m — mounting force developed;

S_m — surface area of thermoelectric coolers within assembly unit;

N_m — number of thermoelectric coolers in the assembly unit;

N — number of screws used for mounting of assembly unit;

K — superficial friction factor (for example, $K=0.2$ for steel, $K=0.15$ for nylon);

d — rated screw diameter.



8. Metallized TEC Mounting

1. Prepare the surface of heatsink — by grinding or polishing obtain the flatness at least of 25 micron on the linear dimension of TEC being mounted. Prior the installation clean thoroughly the surfaces of thermoelectric cooler and heatsink.



2. The heatsink surface shall be suitable for soldering, i.e. the heatsink shall be manufactured of or coated by adequate material, for example, by copper or nickel. After cleaning the heatsink surface should be tinned with assembly solder (type of solder is given if TEC specifications) and moistened with flux.
3. Degrease the surface of the cooler being installed and apply thin layer of flux on it. Heat the preliminarily tinned and cleaned heatsink surface up to the temperature exceeding by 5–10°C the temperature of assembly solder (given in TEC specifications). Put the cooler onto the heatsink surface and wait for several seconds in order that the solder on the cooler melts, and the excessive flux evaporates. When all the solder is melted the cooler will tend to float on the solder. Slight blow-off and hold down of the cooler will improve its installation.
4. Cool the assembly unit and cure the solder. In case more than one cooler is used in the assembly unit, these coolers shall be held down with an object having the surface of the required size with the required tolerance on flatness during the soldering.

9. TEC Connection to Power Supply Source

To determine the negative and positive terminals of a KRYOTHERM TEC, it is recommended to place the TEC face down so that its side equipped with protruding electrodes or lead wires is the TEC bottom. The protruding electrode/ lead wire on your right is positive, whereas the electrode/ lead wire on your left is negative. When TEC is supplied with DC current, its bottom side becomes hot and its upper side gets cold.

With sealed TECs, it might be difficult to determine which TEC side is equipped with lead wires because the TEC is sealed along its perimeter. In this case the colour of the lead wire is a guide, which makes it possible to distinguish between the TEC positive terminal, which has red gauge attached, and its negative terminal with black gauge attached, if not specified otherwise.

The positive and negative module leads should be connected to the respective positive and negative terminals of a DC power source.

Single stage TECs are current — reversible. In other words, reversing the TEC polarity will swap the TEC cold side into the hot one and vice versa. When TEC polarity is used, additional heat penetration along the lead wires to the TEC side equipped with the lead wires should be taken into consideration.

10. Power Supply Considerations

Thermoelectric coolers (TECs) should be powered from the direct current source. We recommend for efficient cooler operation the level of current flutter does not exceed 5% (maximum allowed level is 10%).

If it is necessary for multistage coolers to obtain the substantial temperature drop, the level of flutter shall not exceed 2%. It is recommended also to reduce in maximum extent possible the level of flutter in the power supply circuit of TECs used as coolers for precision receivers and parametric devices.

Using the regulated DC power supply coolers it is possible to obtain the accuracy of temperature maintenance on the object being cooled equal to $\pm 1^\circ\text{C}$. If more accurate temperature stabilization is required, temperature control unit is included into power supply circuit of TEC providing for feedback of the object being cooled with the power supply unit. Such circuits permits to maintain the temperature of the object with accuracy from 0.5 to 10^{-5}°C depending on the type of the control unit used and of the power supply unit.

In number of cases the power supply coolers with pulse duration modulation (PDM) of output voltage are used for TEC



power supply. Due to significant inertia (lagging) of thermal processes in comparison with electric ones the recommended modulating frequency should not exceed 0.5 Hz. In case high frequency PDM is used (from 1 to 100 kHz) it is required to integrate the capacitor of adequate capacity into the power supply circuit of TEC in order to reduce the level of flutter.



11. Supply Voltage Considerations

TEC operating mode — the required maximum cooling capacity and efficiency — predetermine the voltage rating to be supplied per one module. It is highly important to remember that the supplied voltage per TEC should not exceed the maximum voltage (U_{max}) specified for this particular type of TEC.

For example, in the case of high performance TECs such as FROST, SNOWBALL, and ICE series with the U_{max} being equal to appr. 16 Volts, we recommend to feed the TECs with 12 Volts, which is around 75% of their specified U_{max} . We consider this way of choosing TEC voltage to be optimal to provide large cooling capacity (Q_c) at high-rated efficiency of a TE module. Coefficient of performance (COP) is a measure of the efficiency of a TEC and is defined as TEC cooling capacity (Q_c) divided by the electric input power (P). When KRYOTHERM high performance TECs are supplied with over 12 Volts, the increase in TEC cooling capacity is negligible and COP of a TEC drops.

To provide high COP of a thermoelectric system that operates on a relatively low ΔT ($\Delta T \ll \Delta T_{max}$), it is

recommended to mount several TECs into the system to supply each of the TECs with a lower voltage of around 6 to 9 Volts. If the need arises to increase specific cooling capacity of FROST, SNOWBALL, or ICE TECs, the TECs should be supplied with over 12 Volts with the generated heat being effectively dissipated from the TEC hot side.

The same principle of voltage optimization to supply TECs with 75% of their U_{max} is applied to all the modules, although their U_{max} may be different from the one mentioned above. At the same time, heat dissipation from the hot side and power supply characteristics should necessarily be taken into consideration in each particular case.

With high performance powerful TECs of DRIFT series, the optimal supplied voltage ranges 12–18 Volts to achieve great cooling capacity at the highest possible COP value, which is vital for such applications as CPU cooling.

When calculating electrical parameters of a TEC working point, it should be noted that once the TEC is in its running mode, the input current goes down 20–35%. According to the Seebeck effect, the increase in temperature differential between the TEC hot and cold sides results in greater thermal emf. This leads to smaller voltage drop and, consequently, reduction in current running across the TEC.

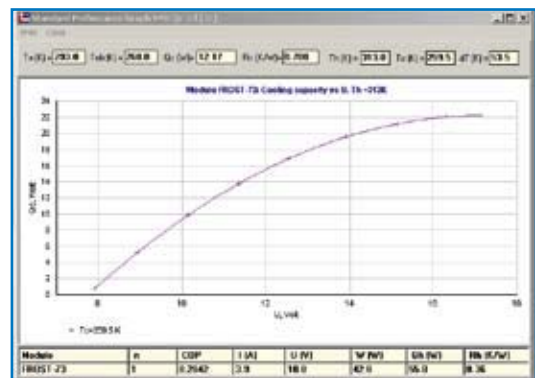
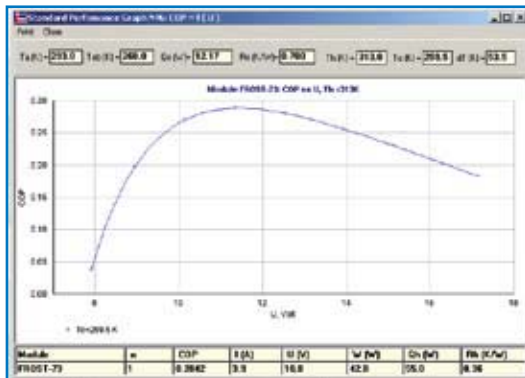

"Kryotherm" Software



"Kryotherm" Software is specially developed for optimization of thermoelectric coolers selection and cooling systems design.

On base of many years' communication with customers we choose the following questions most often asked by our customers:

1. What are the specific operating features of this particular TEC?
2. How many coolers are required for my task, and of what type?
3. What will be the result if these coolers are used in the existing cooling system?

"Kryotherm" software will help to answer these questions. The software includes three sections:

"Performance Graphs". This section presents the graphs of dependencies of thermoelectric cooler parameters in various combinations under different operating conditions.

"Choice of Modules". This section will help to select optimal (from point of view of power consumption or cost) type and number of thermoelectric coolers for the particular system specifying its main heat-transfer and electrical parameters (synthesis).

"Thermoelectric System". Using his section it is possible to create the computer model of the particular system and to perform the analysis of its operation depending on type and number of thermoelectric coolers used in it, variants of their connection, supply voltage, etc. (analysis). After starting the file **Kryotherm.exe** these sections can be found in main menu of the software main window.

Besides the parameters themselves of thermoelectric coolers of Kryotherm Company and the possibility to calculate the systems on their base, "Kryotherm" software includes the algorithms for calculation of thermal insulation and calculation of heat exchanger parameters. All this permits to solve virtually any tasks of thermoelectric cooling using Kryotherm software — from calculation of domestic refrigerators and liquid coolers to cooling systems of computer processors, night vision devices, etc.

In **Help** section of "Kryotherm" software there are the detailed instructions on its use in English and Russian languages. There is a possibility in this software to save the parameters of the thermoelectric system being designed in the separate file for their subsequent use or transfer. In case any difficulties arise during solving of some particular task, it is possible to transfer the design data to specialists of Kryotherm Company using this option. They will help to find the correct solution of any particular problem.

We are sure that "Kryotherm" software will become the reliable assistant in application of thermoelectric coolers and will help to implement the wide possibilities offered by thermoelectricity.

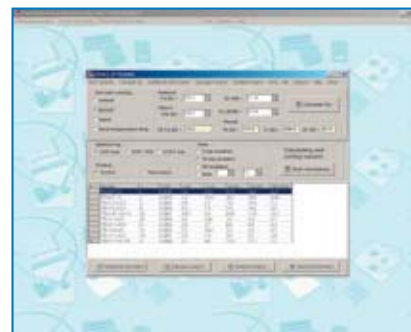

Fig. 1. "Performance graph standard"

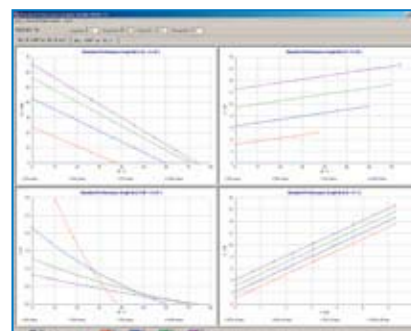

Fig. 2. "Performance graph detailed"

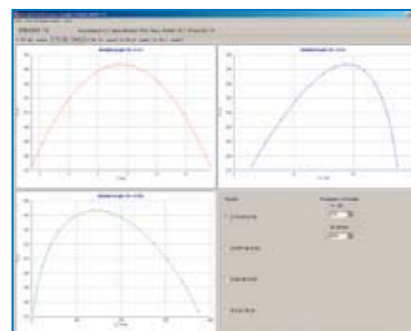
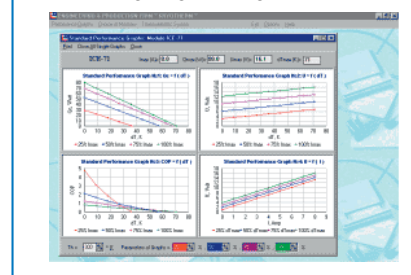
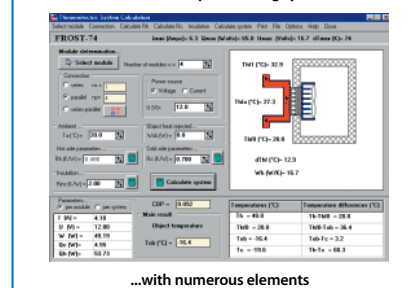

Fig. 3. Choice of Modules

"Kryotherm" software permits to perform calculations, beginning from a single TEC ...



... and till to complex cooling system ...



...with numerous elements



Customer request form

In order that the specialists of KRYOTHERM can be able to offer the optimal thermoelectric cooler for your particular requirements, please fill the application below.

Please attempt to fill all the sections of this application in order that all the required parameters of the cooler can be taken into account during cooler production.

1. Field of application of thermoelectric coolers (home appliances, medical equipment, lasers, etc.)

--

2. Performance Requirements

Heat load:	
passive (W)	
active (W)	
momentary (W) (peak)	
Volume and mass of the object being cooled	
Total heat load (W)	
Required temperature of the object being cooled	
Type of heat heat used (heatsink air cooling, water cooling, etc.)	
Thermal resistance of heat diverter	
Ambient temperature	

3. Electrical Requirements

Specifications	Desired values	Max allowed
Current		
Voltage		
Power		

4. Dimensional Requirements

	Desired values	Minimum allowed	Maximum allowed	Manufacturing tolerance
Lenght				
Width				
Height				

5. Ceramics substrate

	Aluminium oxide (Al ₂ O ₃)	Aluminium nitride (ALN)
Cold side		
Hot side		

Customer request form



6. Assembly Temperature of thermoelectric cooler on your product

T processing	
--------------	--

7. External Finishing

	Cold side	Hot side
Without metallization		
Metallized		
Copper/nickel		
Copper/nickel/gold		
Tinned (solder temperature)		

8. Wires

Wire length	
Wire type	
Tinning of wire ends	

9. Special requirements

Additional tests on your request (please, give brief description of the experiment)	
Cooler connection into "chains"	
Requirements to packing	

10. Required quantity of thermoelectric coolers and preferred date of delivery

--

11. Other requirements

--



